

# Operating Instructions

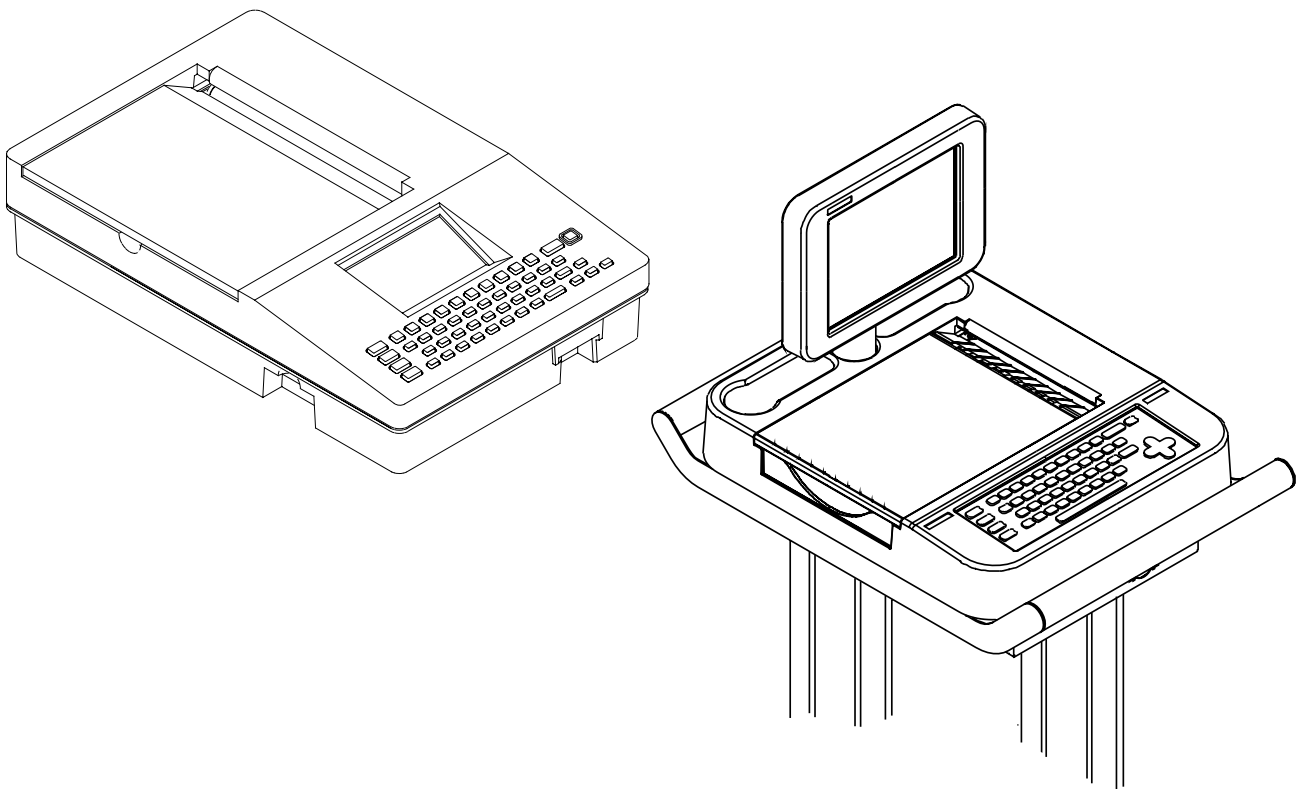

## **Eclipse™ 850 & Plus Electrocardiographs**

Operating Instructions Part No. 070-1046-00  
Rev. A

## DISCLAIMER

SPACELABS BURDICK, INC. MAKES NO REPRESENTATIONS OR WARRANTIES WITH RESPECT TO THE CONTENTS OR USE OF THIS MANUAL, OR WITH RESPECT TO ANY SPACELABS BURDICK, INC. HARDWARE OR SOFTWARE, AND EXPRESSLY DISCLAIMS ANY EXPRESS OR IMPLIED WARRANTIES OF MERCHANTABILITY OR FITNESS FOR A PARTICULAR PURPOSE.

---

---

Copyright © 2001 Spacelabs Burdick, Inc. All rights reserved.  
Printed in the United States of America.  
No part of this publication may be reproduced, photocopied or transmitted without the express written consent of the publisher.

Spacelabs Burdick, Inc.  
500 Burdick Parkway  
Deerfield, Wisconsin 53531 U.S.A.  
(800) 777-1777 (608) 764-1919

Authorized EC Representative  
Spacelabs Medical SARL  
6, allée des Saules  
94042 Créteil  
FRANCE

Telephone: 33 (0) 1 45.13.22.44  
Fax: 33 (0) 1 45.13.22.00

# Quick Reference Instructions

## CONNECT PATIENT

Refer to lead placement chart

## POWER ON...

Press 

Wait for ECG screen and

confirm "SENSORS OK" message.

If no response or "LOW BATTERY" appears, plug power cord into AC outlet.

## FOR A STAT ECG...

Press 

## ECG W/PATIENT INFORMATION...

Press 

Type patient's ID#

Press 

Type patient's LAST NAME

Press 

Type patient's FIRST NAME

Press 

Type patient's DATE OF BIRTH

example: 04  14  1952

Press 

Press  or 

Enter remaining patient information

Press 

Verify waveforms on screen

Press 

## FOR A CONTINUOUS RHYTHM PRINTOUT

Press 

Press  to stop rhythm printing.

## PRECORDIAL LEAD PLACEMENT

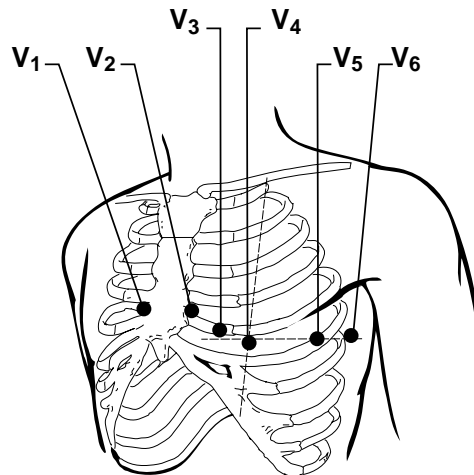

**V<sub>1</sub>** Fourth intercostal space at right margin of sternum

**V<sub>2</sub>** Fourth intercostal space at left margin of sternum

**V<sub>4</sub>** Fifth intercostal space at junction of left midclavicular line

**V<sub>3</sub>** Midway between position V<sub>2</sub> and position V<sub>4</sub>

**V<sub>5</sub>** At horizontal level of position V<sub>4</sub> at left anterior axillary line

**V<sub>6</sub>** At horizontal level of position V<sub>4</sub> at left midaxillary line

## LIMB LEAD PLACEMENT

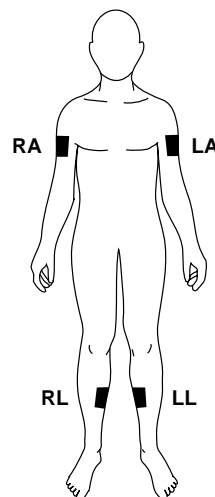



---

---

# Table of Contents

	Table of Contents .....	i
	Intended Use .....	iii
	Warnings, Cautions & Notices.....	iv
	Definitions of Symbols Used.....	vi
<b>Chapter 1</b>	<b>General Information .....</b>	<b>1-1</b>
	Inspection Upon Delivery .....	1-1
	General Description .....	1-2
	Interpretive Analysis Program .....	1-3
	Safety Features .....	1-4
	Using Multiple Electrical Apparatus .....	1-4
<b>Chapter 2</b>	<b>Equipment Setup .....</b>	<b>2-1</b>
	Equipment Connections .....	2-1
	Equipment Setup .....	2-4
	Turning the Unit On .....	2-7
<b>Chapter 3</b>	<b>Keyboard and Displays .....</b>	<b>3-1</b>
	The Keyboard .....	3-1
	The PREVIEW Screen .....	3-4
	A sample menu—the EDIT ID menu .....	3-6
	Using Menus .....	3-8
	Lists and System Notes .....	3-9
<b>Chapter 4</b>	<b>System Setup and User Setup .....</b>	<b>4-1</b>
	Configuring SYSTEM SETUP Menu .....	4-1
	Configuring the USER SETUP Menus .....	4-5
	Acquiring a Printout of Eclipse Program Settings .....	4-16
<b>Chapter 5</b>	<b>Patient Preparation .....</b>	<b>5-1</b>
	Choosing the environment .....	5-1
	Preparing Patients for Resting ECGs .....	5-1
	Resting ECG Lead Placement & Coding Chart .....	5-3
	Alternative Lead Placements .....	5-7
	Preparing Patients for Exercise Stress Testing .....	5-10
<b>Chapter 6</b>	<b>Acquiring ECG Reports .....</b>	<b>6-1</b>
	Acquiring a Stat ECG .....	6-1
	Acquiring an Auto ECG .....	6-2
	Printing Reports .....	6-4
	Temporarily Changing Current Settings .....	6-5
	Acquiring an Auto Rhythm or a Manual Rhythm .....	6-6
	Acquiring an ECG Using Alternative Lead Placements .....	6-7
	Entering Patient Demographics .....	6-9

---

<b>Chapter 7</b>	<b>Managing Patient Records</b> . . . . .	<b>7-1</b>
	Using the DIRECTORY Menu . . . . .	7-1
	Accessing Saved Files . . . . .	7-3
	Additional Functions . . . . .	7-6
<b>Chapter 8</b>	<b>Sending and Receiving Records</b> . . . . .	<b>8-1</b>
	How record status affects the sending operations . . . . .	8-1
	Changing Record Status . . . . .	8-1
	Setting up the Unit to Send and Receive . . . . .	8-2
	Receiving requisitions from PYRAMIS . . . . .	8-4
	Sending records to PYRAMIS . . . . .	8-5
	Sending and Receiving records from an Eclipse . . . . .	8-6
	Receiving records from PYRAMIS . . . . .	8-6
<b>Chapter 9</b>	<b>Sample Printouts</b> . . . . .	<b>9-1</b>
	Print Directory Report . . . . .	9-1
	Print Setup Report . . . . .	9-2
	Standard 12-Lead, 4-Channel Auto ECG (Eclipse 850) . . . . .	9-5
	Standard 12-Lead, 6-Channel Auto ECG (Eclipse 850) . . . . .	9-6
	Standard 3-Channel Rhythm & Manual ECG (Eclipse 850) . . . . .	9-8
	Standard 12 Channel Rhythm & Manual ECG (Eclipse Plus) . . . . .	9-9
<b>Chapter 10</b>	<b>Troubleshooting</b> . . . . .	<b>10-1</b>
	Troubleshooting Basic Unit Problems . . . . .	10-1
	Troubleshooting Trace Problems . . . . .	10-2
	Troubleshooting Printer Problems . . . . .	10-3
	Recognizing and Reducing ECG Artifacts . . . . .	10-4
<b>Chapter 11</b>	<b>Maintenance and Service</b> . . . . .	<b>11-1</b>
	Calibrating the Battery Status Gauge . . . . .	11-1
	Inspecting for Damage . . . . .	11-2
	Cleaning and Disinfecting the Eclipse . . . . .	11-2
	Testing Equipment . . . . .	11-3
	Notice to responsible service personnel . . . . .	11-5
	Performance Disclosures . . . . .	11-5
	Technical Specifications (Eclipse 850) . . . . .	11-7
	Technical Specifications (Eclipse Plus) . . . . .	11-9
<b>Chapter 12</b>	<b>Measurement Matrix</b> . . . . .	<b>12-1</b>
	Index . . . . .	IN-1

---

---

## *Intended Use*

**WARNING:** *The Eclipse should not be connected to non-medical equipment unless the non-medical equipment complies with IEC 601-1. In addition, the enclosure leakage current of non-medical equipment connected to the Eclipse should not be allowed to exceed 500 $\mu$ A in fault condition. To maintain a proper enclosure leakage current, provide additional protective earth grounding, use an additional isolating transformer or use a floating power supply.*

**WARNING:** *The Eclipse and any non-medical equipment that it is connected to should not be allowed within the patient's vicinity, which extends 6 feet (1.83 m) beyond the perimeter of the bed, table or chair, and 7 1/2 feet (2.29 m) above the floor.*

**WARNING:** *NEVER create a direct connection between an Eclipse and a PYRAMIS computer if the Eclipse is already connected to a patient.*

Under the supervision of a qualified physician trained in the subject of ECG interpretation, the Eclipse 850 and Eclipse Plus can be used to record the electrical activity of the heart for the purpose of correlating the resultant waveforms with the health of the heart muscle tissue structures.

This equipment produces a 12 lead (view) electrocardiogram which can be used as a first step for assessment of patients with cardiac arrhythmias, intraventricular conduction block, pre-excitation syndrome and ischemic heart disease. Records stored and used during the life of the patient can assist physicians in the diagnosis and natural history of heart related illnesses (such as coronary artery disease).

With appropriate support equipment, the Eclipse 850 can also be used in the evaluation of exercise induced ischemia of the heart typically referred to as an exercise stress test. The resultant electrical activity of the heart can be recorded as a 12 lead and further analyzed for ischemic episodes.

This equipment is not designed to produce a definitive interpretation nor an exhaustive evaluation of the patient's heart but rather provide an effective beginning for evaluation of patients with heart abnormalities.

---

---

## Warnings, Cautions & Notices



### Warnings

**WARNING:** The Eclipse should not be connected to non-medical equipment unless the non-medical equipment complies with IEC 601-1. In addition, the enclosure leakage current of non-medical equipment connected to the Eclipse should not be allowed to exceed  $500\mu\text{A}$  in fault condition. To maintain a proper enclosure leakage current, provide additional protective earth grounding, use an additional isolating transformer or use a floating power supply.

**WARNING:** The Eclipse and any non-medical equipment that it is connected to should not be allowed within the patient's vicinity, which extends 6 feet (1.83 m) beyond the perimeter of the bed, table or chair, and 7 1/2 feet (2.29 m) above the floor.

**WARNING:** NEVER create a direct connection between an Eclipse and a PYRAMIS computer if the Eclipse is already connected to a patient.

**WARNING:** This device is NOT intended for unattended or continuous patient monitoring. It is intended for short-term ECG waveform acquisition. There are no audible or visible alarms.

**WARNING:** Never remove the battery pack and attempt to recharge it using an external battery charger. Fire or explosion may result.

**WARNING:** Explosion hazard. Do NOT use in the presence of flammable anesthetics.



**WARNING:** Electrical shock hazard. Do NOT contact unit or patient during defibrillation. Otherwise, serious injury or death could result.

**WARNING:** NEVER position defibrillator paddles very close to or over ECG sensors. Remove all chest sensors (V-Leads/C-Leads) from a patient before defibrillation to allow proper paddle placement. Severe burns may result from improper placement of defibrillator paddles. Before using any defibrillator, consult the operating instructions for that equipment.

**WARNING:** Electrical shock hazard. Operate the unit from its battery supply if the integrity of the protective earth conductor is in doubt. Otherwise, serious injury or death could result.

---

---

**WARNING:** If safety procedures not performed, increased risk to patient and device can occur.



**WARNING:** Hazardous voltage. To reduce the risk of electrical shock, do not attempt to remove the cover under any circumstances. Refer servicing to a qualified technician.

## Cautions

**CAUTION:** Federal law restricts this device to sale by or on the order of a physician

**CAUTION:** The unit must be operated only at the line voltage and frequency specified on the rating plate.

**CAUTION:** Although the Eclipse is designed to meet IEC 601-1-2 EMC immunity requirements, the presence of strong EMI fields generated by electronic, surgical or diathermy instruments in close proximity to the unit may cause trace noise or input overload conditions.

**CAUTION:** Fire hazard. Use only approved battery packs. Replace Eclipse 850 battery pack with the battery specified on the label inside the battery compartment.

## Notices

**NOTICE:** Do not place used battery pack in your regular trash. The incineration, landfilling, or mixing of NiCad batteries with municipal waste is PROHIBITED BY LAW in most areas. Return this battery pack to a government-approved battery recycler. Contact your local waste management officials for more information.

**NOTICE:** Computer assisted interpretation is a valuable tool when used properly. However, no automated interpretation is completely reliable and interpretations should be reviewed by a qualified physician before treatment, or non-treatment, of any patient.

**NOTICE:** Because the Eclipse offers different lead configurations, always ensure that the appropriate lead placement is employed for the lead configuration selected.

**NOTICE:** Waveforms displayed on the Eclipse screen are not intended to be used for diagnostic purposes. Use displayed waveforms to assess signal quality only.

**NOTICE:** Damage caused by using unapproved recording paper may void your warranty. Your Eclipse Electrocardiograph is intended for use with approved ECG supplies; its reliability and performance are directly affected by the supplies you use.

---

---

## *Definitions of Symbols Used*

### **Safety Symbols**



Attention. Consult accompanying documents.



Danger! High voltage.



Hazardous voltage.



Defibrillation-Protected Type CF Equipment.



Equipotentiality (used to label the grounding lug).



Complies with the EMC/Radiocommunications requirements set out by the Australian Communication Authority under Radiocommunications Act, 1992.















Meets or exceeds Council Directive 93/42/EEC, MDD, Class IIa.

---

---

## Labeling Symbols

	Alternating Current (AC)
	Automatic Operation
	Custom Lead Triplet
	Frequency Response
	Heart Rate
	Input/Output Connection
	LCD Screen Contrast
	Manual Operation
	On/Standby
	Stop Function
<b>I/O</b>	Serial port
	Battery Compartment
	Battery Charge Status
	Modem
<b>RJ11</b>	Modem

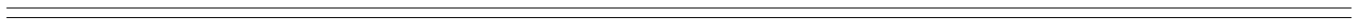

Congratulations on your purchase of a top quality Eclipse ECG machine.

By listening to our customers, we have designed the Eclipse to suit your specific needs, incorporating features that people like yourself have requested.

Your business is important to us. If you would like more information or if you have any questions, contact your local representative or Spacelabs Burdick Technical Support Department at (800) 522-7025, (425) 882-3700 or (608)764-1919.

***CAUTION:*** *Federal law restricts this device to sale by or on the order of a physician.*

## **Inspection Upon Delivery**

Your new Eclipse was carefully inspected before shipment. Please inspect your unit upon delivery for any damage which may have occurred in transit. If you notice any damage, please contact your shipping agent.

If items are missing, contact your local representative or Spacelabs Burdick Technical Support Department at (800) 522-7025, (425) 882-3700 or (608)764-1919.

**NOTE:** Your Eclipse Electrocardiograph is intended for use with approved ECG supplies; its reliability and performance are directly affected by the supplies you use.

## General Description

*Figure 1-1*  
*Eclipse 850*  
*and Eclipse Plus*

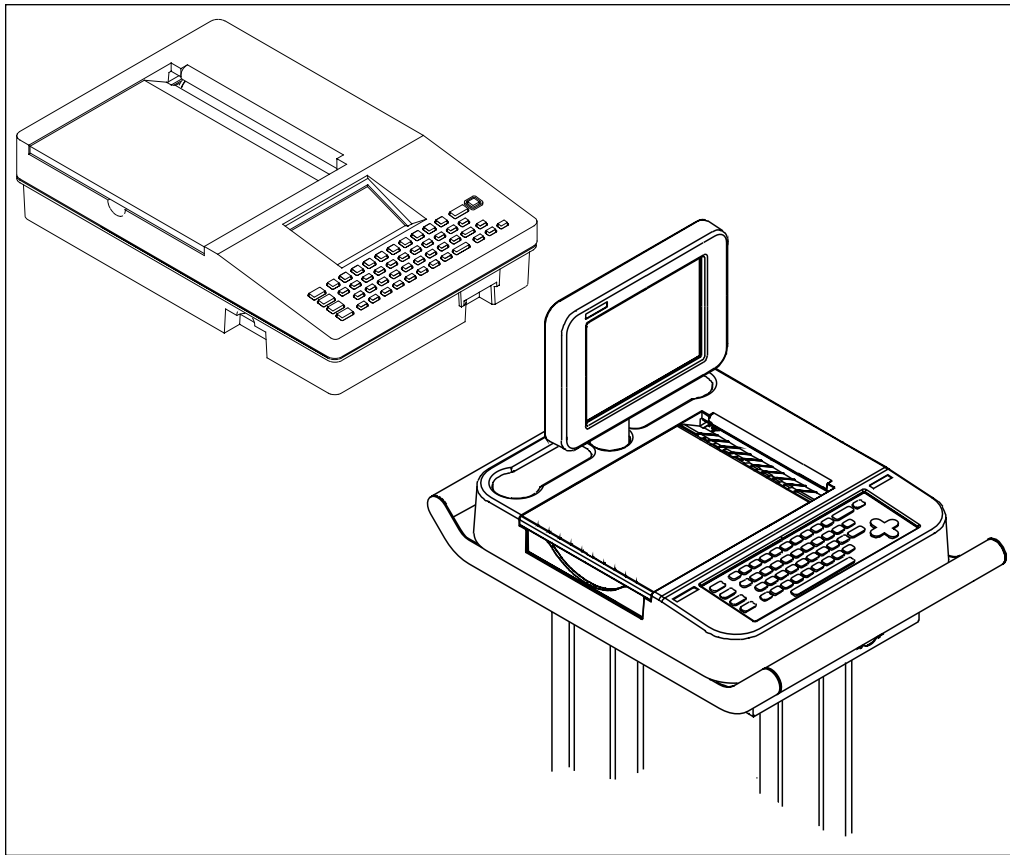

- Portable; may be operated from battery or AC line power.
- Eclipse Plus features an active-matrix color LCD.
- Eclipse 850 features a backlit, grayscale LCD.
- Prints using a thermal printer and thermosensitive, Z-fold paper.
- Operates in manual and automatic modes.
- Records in either standard or Cabrera lead formats. Alternative lead selections include Pediatric ( $V_4R$ ), Alternate Chest Lead, Nehb, and Frank.
- Stores and, with interpretive models, analyzes waveforms acquired in automatic mode.
- Prints at least 200 pages at 25 mm/s recording speed when the internal battery is fully charged.
- Continuously recharges the battery whenever the unit is connected to AC line power.
- Enhanceable. Software enhancements are quickly and easily introduced.
- Allows you to preview waveforms before you print, saving time and supplies.
- Features selectable patient demographic fields that you may use to suit your needs.

## Interpretive Analysis Program

### About the program

The Eclipse is available with an interpretive analysis program. This program is widely respected as one of the most accurate available today. It was developed by Prof. Peter MacFarlane of the Glasgow Royal Infirmary who has been involved in computerized ECG interpretation since its inception in the 1960s.

The ECG Interpretation Criteria Physician's Guide is included with the Operating Instructions. This guide outlines the criteria used by the analysis program.

### Features of the interpretive analysis program

- **DEVELOPED IN A HOSPITAL ENVIRONMENT**  
The interpretive program was developed in the University Department of Medical Cardiology in the Glasgow Royal Infirmary. Unlike many products which are developed with the aid of outside consultants, this program was developed in the environment for which it is intended.
- **USES AGE, SEX AND RACE DATA EXTENSIVELY**  
More than 500 measurements, plus the patient's age, sex, race, clinical classification and medications are factored into each analysis. Several criteria for abnormalities are age, race and sex dependent. Race, for example is key in identifying hypertrophy and T-wave abnormalities.
- **USES CLINICAL HISTORY**  
The program is the first to use clinical class as an integral part of analysis just as a physician would consider clinical class in his or her evaluation.
- **UNDER CONTINUOUS DEVELOPMENT & ENHANCEMENT**  
The program has been clinically tested against more than 80,000 ECGs and is continuously under development.
- **ACCURATELY DETECTS NORMAL ECGs**  
Normal ECGs are easily identified and sorted so the physician may quickly verify results.

## Safety Features



**WARNING:** *Electrical shock hazard. Do NOT contact unit or patient during defibrillation. Otherwise, serious injury or death could result.*



**WARNING:** *NEVER position defibrillator paddles very close to or over ECG sensors. Remove all chest sensors (V-Leads/ C-Leads) from a patient before defibrillation to allow proper paddle placement. Severe burns may result from improper placement of defibrillator paddles. Before using any defibrillator, consult the operating instructions for that equipment.*

Includes a 3-conductor, hospital-grade power cable. Includes an electrically isolated, DB-15 style patient cable. This conforms to IEC safety, pinout and mechanical requirements.



This symbol which appears on the rear panel, indicates this equipment meets the requirements of Council Directive 93/42/EEC, MDD, Class IIa.



This symbol next to the patient cable connector indicates this equipment is classified as defibrillation-protected, Type CF equipment. The patient cable and input circuits are designed to prevent damage to the recorder if the unit is connected to a patient during defibrillation.

## Using Multiple Electrical Apparatus

Use caution when monitoring patients who must be protected from very small electrical currents. Susceptible patients include patients with cardiac catheters or pacemakers. Consult a qualified technician before using multiple electrical apparatus in this patient environment.

The Eclipse patient leads are electrically isolated from ground and the device meets the most stringent IEC and ANSI/ AAMI medical standards for leakage currents.

However, a potential hazard may occur if the enclosure leakage currents from multiple pieces of equipment combine and are inadvertently routed directly to a patient's heart via a catheter or pacemaker lead. Only equipment which is certified to IEC and ANSI/ AAMI medical standards should be used in this environment. Use of certified equipment does not, however, completely eliminate this possible hazard.

Another potential hazard may occur if two devices near a patient are powered from different circuits. If the grounds of the two circuits are at different potentials, which can occur under certain fault conditions, then a ground loop can exist between the enclosures of the two devices. If devices must be powered from separate circuits in the vicinity of a susceptible patient, then the grounding lugs on the devices should be electrically connected via an equipotential cable. Please also consult Chapter 2, "Equipment Setup."

## Equipment Connections

**WARNING:** *The Eclipse should not be connected to non-medical equipment unless the non-medical equipment complies with IEC 601-1. In addition, the enclosure leakage current of non-medical equipment connected to the Eclipse should not be allowed to exceed 500 $\mu$ A in fault condition. To maintain a proper enclosure leakage current, provide additional protective earth grounding, use an additional isolating transformer or use a floating power supply.*

**WARNING:** *The Eclipse and any non-medical equipment that it is connected to should not be allowed within the patient's vicinity, which extends 6 feet (1.83 m) beyond the perimeter of the bed, table or chair, and 7 1/2 feet (2.29 m) above the floor.*

**WARNING:** *NEVER create a direct connection between an Eclipse and a PYRAMIS computer if the Eclipse is already connected to a patient.*

### Connecting power cord and peripheral equipment



**CAUTION:** *The unit must be operated only at the line voltage and frequency specified on the rating plate.*

Connect AC line power and external equipment via the connectors on the back panel (see Figure 2-1).

For patient safety, all equipment in patient environment should be IEC 601-1 approved. All connected equipment should be IEC 950 approved or equivalent. Consult a qualified technician to verify equipment compatibility.

Figure 2-1  
Eclipse Back Panel

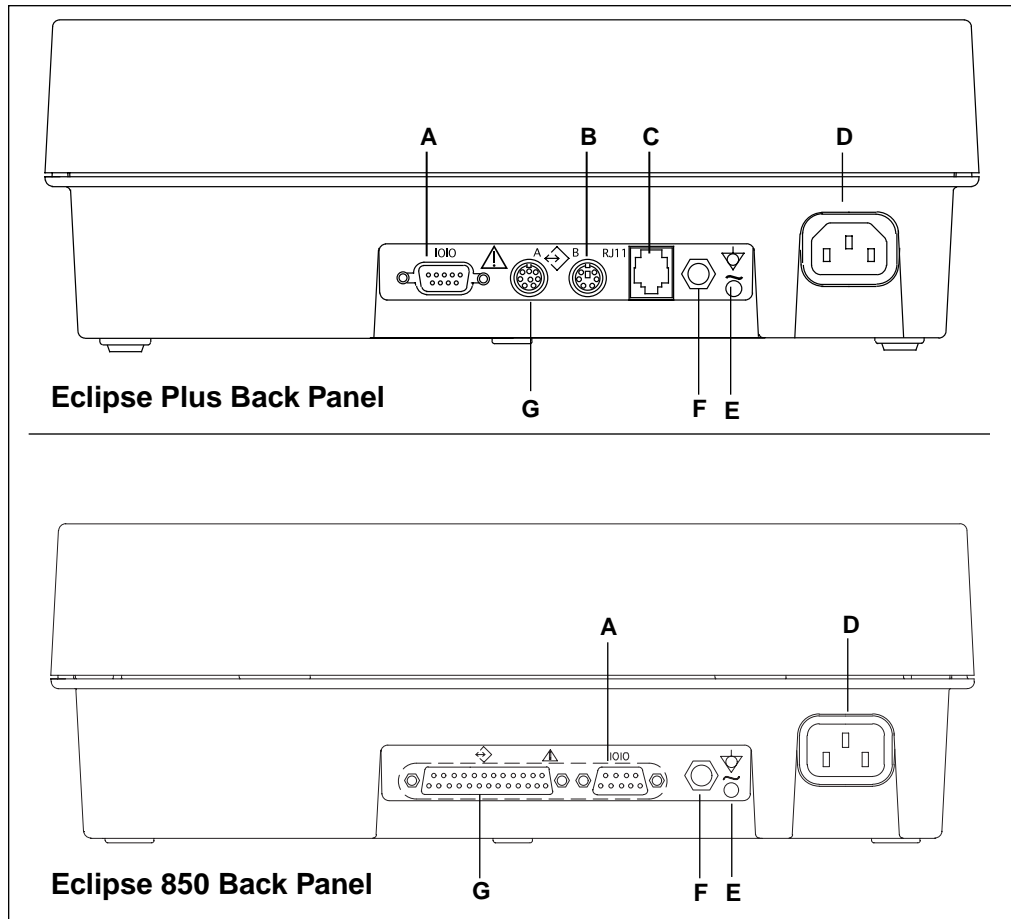

**IOIO (A) SERIAL PORT  
(ECLIPSE PLUS & 850 WITH COMMUNICATIONS)**

Connect compatible fax/modems to this serial connector using an approved modem cable. You must have the fax or SCP-ECG software installed to use this function.

Most Hayes-compatible modems supporting Fax Service Class 2 commands will work with the Eclipse.

This connector is also used for direct connection of the unit to a compatible management system using an approved Direct Connect cable.

**(B) EXPANSION (ECLIPSE PLUS)**

This connector is reserved for future expansion.



(OR) RJ11

**(C) INTERNAL MODEM  
(ECLIPSE PLUS & 850 WITH COMMUNICATIONS)**

Connect the phone line you will be using for faxing or sending records into this **RJ11** connector if your unit is equipped with an internal fax/modem. (On the Eclipse 850, this connector is located on the left side of the unit, if you are facing the unit. See Figure 2-2 on pg. 2-3.)

**(D) AC POWER**

Use the supplied power cord to connect the unit to AC line power here.

There is no switch to disconnect AC line power. To do this you must unplug the unit. The battery is automatically charged whenever the unit is connected to AC line power.

**(E) POWER INDICATOR**

Verify that the unit is receiving AC line power when this green light is on.

**(F) EQUIPOTENTIAL GROUNDING**

Connect peripheral equipment directly to the Eclipse protective earth ground via this post. This is necessary only if peripheral equipment requires equipotential grounding.

**(G) ANALOG OUTPUT /STRESS INTERFACE  
(ECLIPSE PLUS & 850 WITH COMMUNICATIONS)**

On the Eclipse 850, this analog output provides the same 3 channels of waveforms which are currently displayed on the PREVIEW screen. Frank and Nehb are not supported. Alternatively, connect the stress interface using an approved monitor cable via this connector.

On the Eclipse Plus, this analog output provides one channel waveform which is the first channel which is currently displayed on the PREVIEW screen, unless the PREVIEW screen is displaying all 12 leads. In this case, channel II is output.

**Connecting the Patient Cable**

Connect the Patient Cable via the connector on the front of the unit. In the figure below, the Eclipse 850 is shown; however, the connector for the Patient Cable on the Eclipse Plus is in the same approximate location.

**Figure 2-2**  
*Patient Cable Connector*  
*(Eclipse 850 shown)*

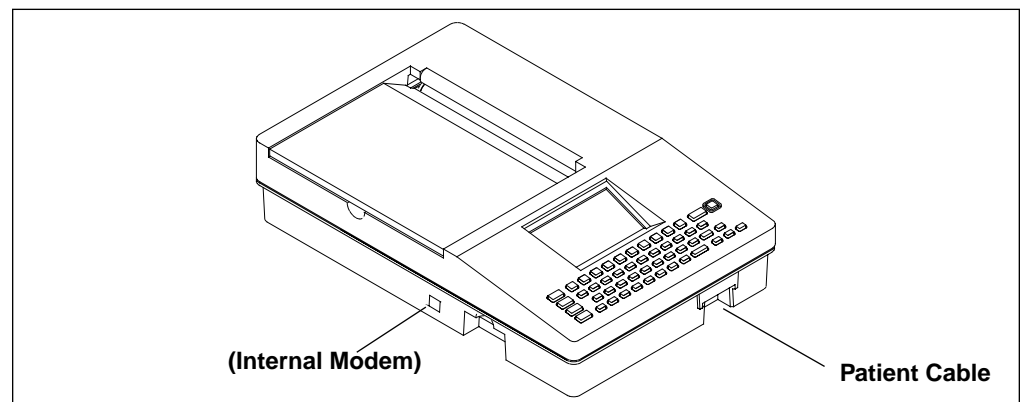

Make sure the connector on the cable is arrow-side-up then firmly push the connector until the arrow point is aligned with the edge of the Eclipse.

## Equipment Setup

### Grounding



**WARNING:** *Electrical shock hazard. Operate the unit from its battery supply if the integrity of the protective earth conductor is in doubt. Otherwise, serious injury or death could result.*

Maximum patient and operator safety is ensured only when the Eclipse is properly grounded. To do this, connect the power cable to the AC Power connector (see Figure 2-1 on pg. 2-2) and connect the other end to a properly grounded, AC line outlet.

### Using the Battery (Eclipse 850)

The battery that is shipped with the Eclipse 850 has been charged at the factory.

When battery power is being used, the message “BATTERY” is displayed. When the unit is connected to AC line power, the message “AC ON” is displayed.

When fewer than 15 minutes of operating time remain, the message “LOW BATTERY” flashes and the unit beeps every 30 seconds. If the battery charge level drops too low, the unit displays the message, “POWERING DOWN.” Then, after 5 seconds, the unit shuts off. Connect the unit to AC line power at this point to operate the unit and recharge the battery (the battery fully recharges in about 5 hours).

**NOTE:** Under extreme conditions, the unit may not have enough battery power to power up. If the unit beeps 3 times or displays the message, “Battery Low-Please Charge” when powering up, then plug the unit into AC line power and recharge the battery for 5 hours.

## Using the Battery (Eclipse Plus)

### CALIBRATION AND CHARGING THE BATTERY

**NOTE:** The battery that is shipped with the Eclipse Plus is not fully charged. To prepare the Eclipse Plus for normal use, follow the procedure below to calibrate the Battery Status gauge and charge the battery.

1. Unplug the Eclipse from AC line power.
2. Press ON/STBY to turn the Eclipse on. Press M to go to the Main menu. Press B, then press Enter to turn on the Battery Exercise Mode.
3. Fully discharge the battery by operating the unplugged unit until the unit powers down from lack of power.
4. Ensure that the battery is discharged by pressing the On/Standby key. If the unit does not turn on or if it powers down within a few seconds, the battery is discharged.
5. Reconnect AC power to fully recharge the battery in about 5 hours.

**NOTE:** You may operate the Eclipse from AC line power while the battery is charging. However, this will increase charging time.

### WHEN TO CHARGE THE BATTERY



During operation of the Eclipse Plus, the Battery Status gauge in the PREVIEW screen tracks battery charge status (see Figure 3-2 on pg. 3-4). When all 8 bars are lit, the battery is fully charged. When battery power is being used, the message "BATTERY" is displayed and the minus sign ( - ) is highlighted indicating that charge is being drained. When the unit is connected to AC line power, the message "AC ON" is displayed and the plus sign ( + ) is highlighted indicating the battery is charging.

When fewer than 15 minutes of operating time remain, the message "LOW BATTERY" flashes and the unit beeps every 30 seconds. If the battery charge level drops too low, the unit displays the message, "POWERING DOWN." Then, after 5 seconds, the unit shuts off. Connect the unit to AC line power at this point to operate the unit and recharge the battery (the battery fully recharges in about 5 hours).

**NOTE:** Under extreme conditions, the unit may not have enough battery power to power up. If the unit beeps 3 times or displays the message, "Battery Low-Please Charge" when powering up, then plug the unit into AC line power and recharge the battery for 5 hours.

## Loading Recording Paper

**NOTE:** Damage caused by using unapproved recording paper may void your warranty.

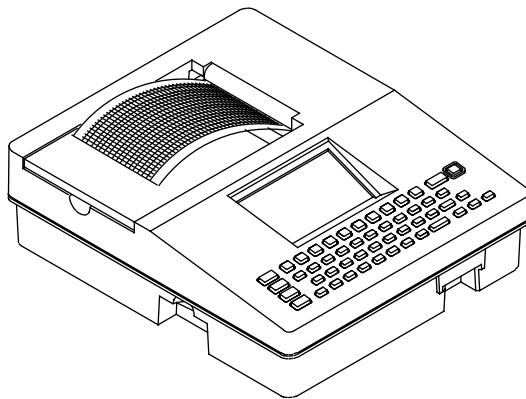
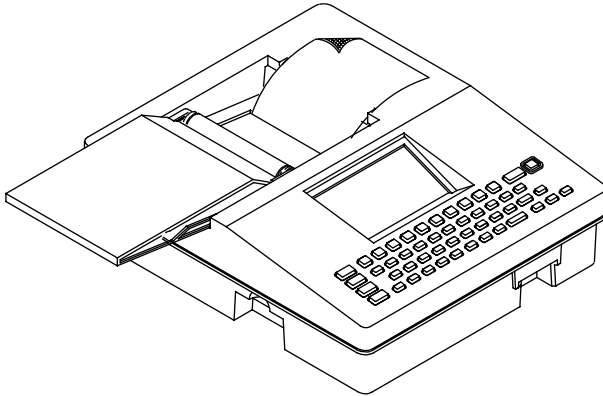

1. Turn the Eclipse on.
2. Open the paper compartment door by lifting and sliding it out to the left.
3. Remove any remaining paper from the paperwell.
4. Lift the top sheet of the new stack of paper and pull it to the right.
5. Place the paper into the compartment.
6. Slide the compartment cover back into place until you notice a definite click as it snaps into the feed rollers.
7. Press the "P" key to advance the paper to the next sheet.
8. Tear off paper by pulling up and to the right. Do not pull additional paper out of the printer.
9. Select the paper type in the System Setup menu (see "Paper Type" on pg. 4-5).

---

**\*Eclipse 4 is shown. The procedure is the same for all Eclipse models.**

---

Use only approved, thermally responsive ECG paper. The following ECG papers are recommended:

1. Assurance 50™. Permanent trace, Z-fold. Thermal image integrity guaranteed for 50 years.
2. Standard trace, Z-fold. Thermal image integrity guaranteed for 5 years when stored in accordance with manufacturer's specifications.

The printer is pre-adjusted at the factory. Do not try to make adjustments.

---

---

## Turning the Unit On



Press the On/Standby key to turn the Eclipse on. The unit performs self-tests and displays the current date and time, a message prompting you to check date and time accuracy, and any error detected during the self-tests.

**NOTE:** To change the date and time settings, see “Configuring SYSTEM SETUP Menu” on pg. 4-1.

After completing self-tests, the unit displays the PREVIEW screen.

## Standby Mode

**NOTE:** The Eclipse will automatically power down to Standby mode after 15 minutes of inactivity.



To power down to Standby mode at any time during operation, press the On/Standby key (there is no switch to disconnect power).

The unit is not operational in Standby mode; however, the internal battery charges in Standby mode if connected to AC power.

The Auto Power Down feature may be temporarily turned off by putting the unit in Battery Exercise Mode.

## Power Indicator



This green light on the back of the unit (see Figure 2-1) is on whenever the unit is receiving AC line power.



Normal operation of the Eclipse Plus and Eclipse 850 occurs through use of the keyboard and LCD display. Alphabetic and numeric keys are used to enter information and are also used as hot keys, to make selections in certain screens. Other keys, such as the ECG key and the arrow keys, provide additional functions, as described in this chapter.

### The Keyboard

Figure 3-1  
The Keyboard and Key Types

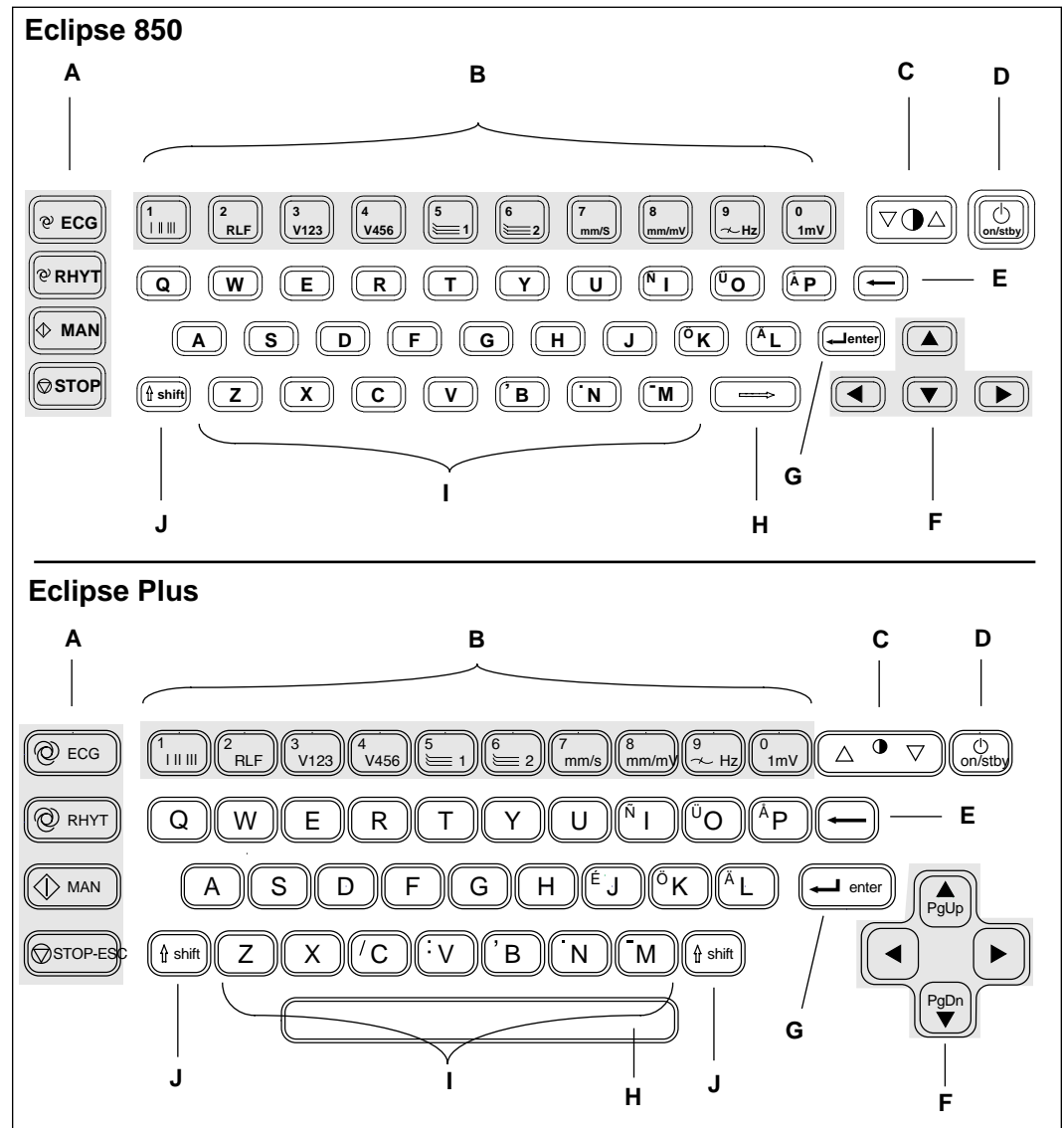

**(A) FUNCTION KEYS**



Use the “ECG” key to acquire and print a 12-lead Auto ECG (a series of reports using pre-programmed lead sequences and settings.)



Use the “RHYT” key to acquire an Auto Rhythm report (a rhythm strip with a pre-selected number of pages; uses the leads currently selected in the PREVIEW screen).



Use the “MAN” key to acquire a Manual Rhythm report (a continuous rhythm strip of the leads currently selected in the PREVIEW screen). This report will run until the “STOP” key is pressed.



Use the “STOP” key to terminate any of the above functions and/or return the display to the PREVIEW screen.

**(B) NUMERIC/ MACHINE CONTROL**

Use the numeric keys to enter numeric data, when required. These keys may also be used as hot keys for specific operations (see “Hot Keys” on pg. 3-9).



Use the “1” and “2” keys to select pre-programmed lead triplets for the display; the displayed leads will also be printed on Manual Rhythm and Auto Rhythm reports.

In the PREVIEW screen, use the “1” and “2” keys with the Shift key to select either User 1 or User 2. See Chapter 4 for user setup information.



Use the “3” and “4” keys to select pre-programmed lead triplets for the display; the displayed leads will also be printed on Manual Rhythm and Auto Rhythm reports.



Use the “5” and “6” keys to select user-defined leads (Custom Lead 1 and Custom Lead 2) for the display; the displayed leads will also be printed on Manual Rhythm and Auto Rhythm reports. See “CUSTOM LEAD 1 & CUSTOM LEAD 2” on pg. 4-9 for setup information.



Use the “7” key to toggle the Paper Speed between 10, 25 and 50 mm/sec.



Use the “8” key to toggle the ECG Gain between 5 mm/mV, 10 mm/mV, 20 mm/mV, L10, C5 mm/mV and L20, C10 mm/mV.



Use the “9” key to toggle the ECG Filter Frequency between 40 and 150 Hz.



Use the “0” key to produce a 1 mV Calibration Pulse on the display and printouts.

**NOTE:** When numeric keys are used to change settings, the settings are in effect for the current ECG only. To change settings for all future ECGs, modify the settings in the USER SETUP menus or the SYSTEM SETUP menu.

**(C) BRIGHTNESS**

Use this key to adjust the brightness of the display.

**(D) ON/STANDBY**

Use this key to turn the unit on. Pressing the On/Standby key again while the unit is on will return the unit to standby mode.

**(E) BACKSPACE**

Use this key to backspace and delete one character behind the cursor, each time the key is pressed.

**(F) ARROW**

Use the Up and Down arrows to move within menus, fields and lists. Hold down the shift key and press the arrows to page up and down in the directory.



Use the Left and Right arrows to enter and exit menus and lists.

**(G) ENTER**

Use the Enter key to accept the current selection.

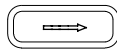
**(H) SPACE**

Use this key to insert a space.

**(I) ALPHABETIC**

**THROUGH**



Use the alphabetic keys to enter information, when required. These keys may also be used as hot keys for specific operations (see "Hot Keys" on pg. 3-9).

To enter punctuation and special characters—such as [ , ], [ . ], [ - ], Ñ, Ü, Ö, Å and Ä—press the Shift key and the corresponding letter.

**(J) SHIFT**

Use the Shift key, along with alphabetic keys, to enter punctuation and special characters. Use the Shift key with the "1" and "2" keys to select either User 1 or User 2.

## The PREVIEW Screen

After the Eclipse has been turned on and performs self-tests, the PREVIEW screen is displayed (see Figure 3-2). General features are described below.

Figure 3-2  
The Preview Screen

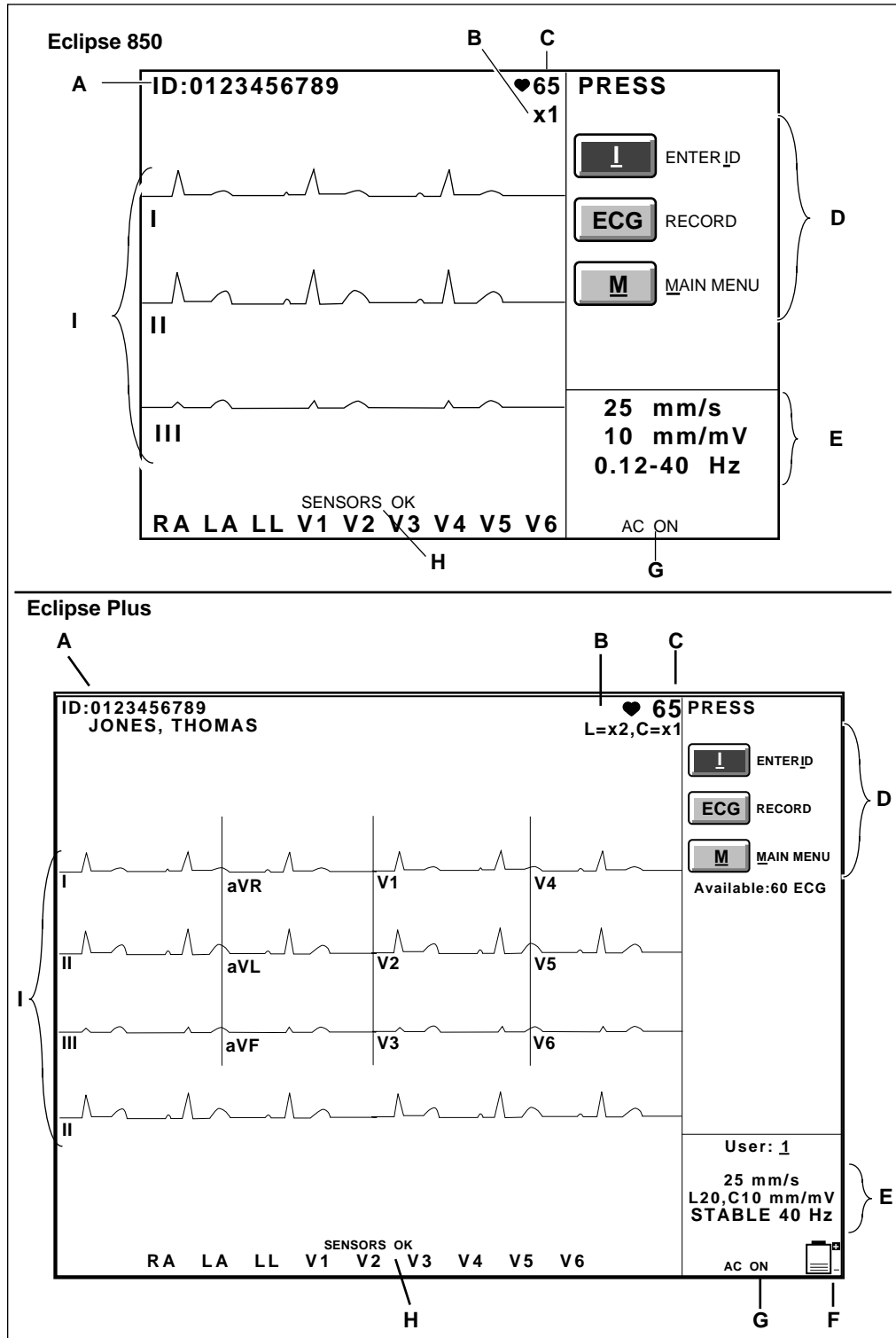

**(A) PATIENT ID**

Identification number of the current patient. On the Eclipse Plus, this field also displays the patient's name.

**(B) RELATIVE GAIN**

Tracks the amplitudes of the displayed waveforms. This corresponds to the Recorder Gain setting as follows:

Recorder Gain	Relative Gain
5 mm/mV	x1/2
10 mm/mV	x1
20 mm/mV	x2
L=10, C=5 mm/mV	L=x1, C=x1/2
L=20, C=10 mm/mV	L=x2, C=x1

**(C) HEART RATE**

Displays the patient's heart rate.

**(D) FUNCTIONS LIST**

Displays available functions and menus. Displays space available (Eclipse PLUS only), for example, "Available: 60 ECG".

**(E) RECORDER SPEED, GAIN AND FREQUENCY RESPONSE**

Displays settings for current ECG reports.

**(F) BATTERY STATUS GAUGE (ECLIPSE PLUS)**

Tracks battery charge level.

**(G) POWER STATUS**

Indicates the power source, AC line power or battery.

**(H) SENSOR STATUS**

Indicates signal quality.

If all sensors are producing good signals, the display reads:

SENSORS OK

If one or more sensors produce a poor signal, the labels for the affected sensors are highlighted and the problem is indicated by one of the following messages:

FAIL  
DRIFT  
NOISE

NOTE: To ensure accurate sensor status indication, the RL electrode must be connected.

NOTE: Refer to Chapter 10, "Troubleshooting" for information on correcting signal problems.

(I) ECG WAVEFORMS

NOTICE: Waveforms displayed on the Eclipse screen are not intended to be used for diagnostic purposes. Use displayed waveforms to assess signal quality only.

This area of the screen displays waveforms for the selected lead group. Until leads are properly connected to a patient, only “flatlines” are displayed.

NOTE: When you select a 6-channel customized lead group on the Eclipse 850, only the first three channels are displayed. However, the “MAN” and “RHYT” keys acquire printouts of all six leads.

### A sample menu—the EDIT ID menu

Most of the Eclipse displays consist of menus. For example, the EDIT ID menu is used to enter patient demographics.



The ENTER ID selection is automatically highlighted when you enter the PREVIEW screen (see Figure 3-2 on pg. 3-4). You may use the up and down arrow keys to highlight other choices and move around in the Functions List.



To go to the EDIT ID menu, make sure the ENTER ID selection is highlighted and either press the Enter key or the right arrow key; pressing the “I” key will also open the EDIT ID menu. The EDIT ID menu is displayed.

Figure 3-3  
A Sample Menu-The  
EDIT ID Menu

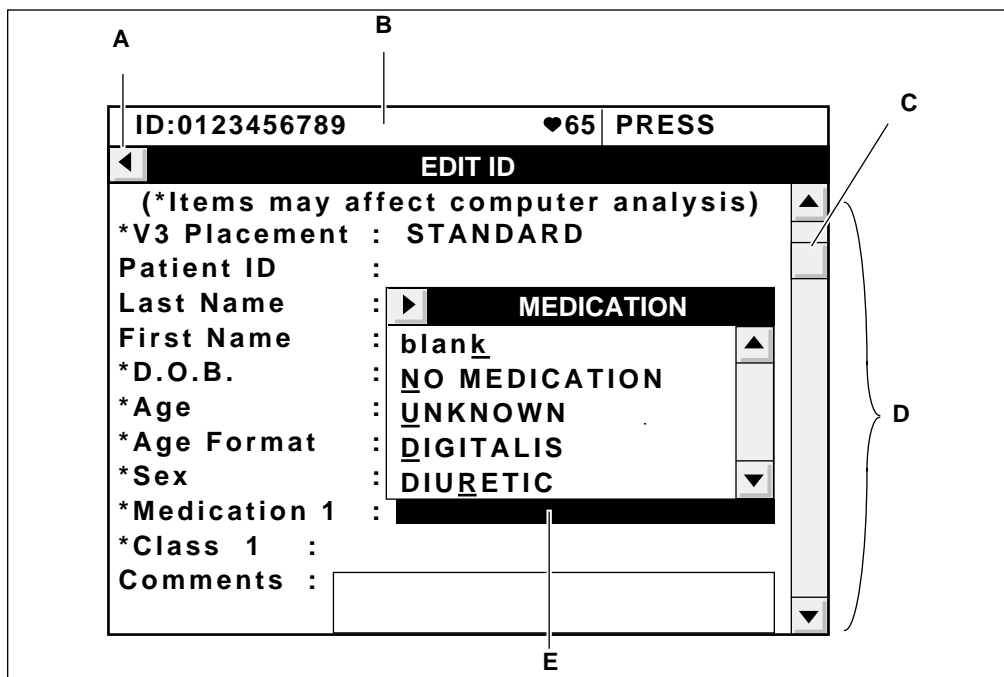

Once you are in the EDIT ID menu, use the up and down arrow keys to select different fields. Pressing the right arrow key in certain fields, such as \*Age Format, will access the list of options for that field. Press the left arrow key to exit the list. Press the left arrow key again to exit the EDIT ID menu.



Following is a description of basic menu features.

**(A) RETURN TO PREVIOUS SCREEN**

The arrow in the upper left corner reminds you that you may return to the previous screen by pressing the Left Arrow key.

**(B) PREVIOUS SCREEN**

The top of the last screen that was displayed shows above all menus.

**(C) SCROLLING BOX**

Located in the Scroll bar, this shows you when the menu continues beyond the current view. The box is at the top when the top field shows. It moves down as you scroll through the menu until the last field shows.

**(D) SCROLL BAR**

Located on the right side of the menu.

**(E) ACTIVE FIELD**

When a field is highlighted you may edit the contents of that field.

## Using Menus



The Up and Down Arrow keys are used to scroll within menus.

Menus are composed of fields. There are three kinds of fields:

1. Alphanumeric
2. Numeric
3. List

### ALPHANUMERIC FIELDS

When active, alphanumeric fields may be filled by typing alphabetic or numeric keys. You may also type spaces, punctuation, and non-English characters. For example, to type the character “Ñ” in the **Last Name** field:

1. Scroll to the **Last Name** field.



2. Hold down the Shift key.



3. Simultaneously press the “I” key.



Press the Enter key after filling fields to accept data and move to the next field.

### NUMERIC FIELDS

When active, numeric fields may be filled by typing numeric keys only. The Eclipse will produce a “beep” sound if you try to type letters or other inappropriate data into a numeric field.



Press the Enter key after filling fields to accept data and move to the next field.

### LIST FIELDS

When active, list fields display a box with a list of choices. These are described in the next section.

### DEFAULTS

Every field has a default setting.

For example, if you skip the **\*Age Format** field it will be filled in with “YEARS.” Unless you make another choice, the Eclipse always uses defaults. Most often, fields are left blank.

## Lists and System Notes

### LISTS

Lists give you all the choices for a particular field. For example, scroll to **Medication 1**. A list appears (see Figure 3-4). The field may be filled with any choice from this list. After you make a selection, the next field becomes active.

Figure 3-4  
A Sample List - The  
Medication List

ID:0123456789		♥65	PRESS
EDIT ID			
(*Items may affect computer analysis)			
*V3 Placement : STANDARD			
Patient ID :			
Last Name :			
First Name :			
*D.O.B. :			
*Age :			
*Age Format :			
*Sex :			
*Medication 1 :			
*Class 1 :			
Comments :			

### HOT KEYS

**NOTE:** If a custom header has been downloaded to the Eclipse unit, then hot keys will not appear in certain lists such as the medication lists.

All list items have hot keys to select them.

For example, the letter “D” is underlined in the choice, “DDIGITALIS.” This is a hot key; it is temporarily specialized to select this choice. Press the “D” key to select “DDIGITALIS”.



Another way to select items is from within the list. You may gain access to the list by pressing the Right Arrow key.

Scroll within the list using the Up and Down Arrow keys. When your choice is highlighted, choose it by pressing the Enter key.



To exit the list without selecting anything, press the Left Arrow key.

### SYSTEM NOTES

System notes give you additional information as needed. For example, a system note appears if you enter data that exceeds an allowed range.

To see a system note, scroll to the **\*Age** field. This is a numeric field that accepts only data between 0 and 364. Try typing a larger number such as 500. A system note box appears.



Press the hot key, "O," to acknowledge the note and continue.

You have just practiced the basics of using the Eclipse. More information accompanies sections for specific functions such as acquiring an Auto ECG.



Press the Left Arrow key to return to the PREVIEW screen and continue working.

## Configuring SYSTEM SETUP Menu

Within the SYSTEM SETUP menu you can select User 1 or User 2, format Eclipse general settings, and set the internal calendar & clock. Setting options are listed in “SYSTEM SETUP Fields” on pg. 4-2.

**NOTE:** Default settings for Eclipse 850 and Eclipse Plus are given on pages 9-3 and 9-4.

### Go to SYSTEM SETUP menu



1. Press the On/Standby key to power up to the PREVIEW screen.
2. Press the “M” key to go to the MAIN MENU.
3. Select SYSTEM SETUP by pressing the “S” key. The SYSTEM SETUP menu will appear (see Figure 4-1).

Figure 4-1  
The SYSTEM SETUP Menu

ID:0123456789	♥65	PRESS
MAIN MENU		
SYSTEM SETUP		
User 1-2 Select: 1		▲
Line Filter: 60 Hz	▶ USER	
Date Format: DD.MM.YY	1	
Date: 12.11.1995	2	
Time: 13:45		
Language: ENGLISH		
Height Units: IN.		
Weight Units: LB.		
Inst. Name:		
		▼

4. Use the up and down arrow keys to scroll through the fields in the SYSTEM SETUP menu. As you scroll through the fields, the options available for each field will be displayed when the field is highlighted.
5. Once a field is highlighted, change the current selection by pressing the hot key associated with the option. For example, to select User 1 in the User 1-2 Select field, press the “1” key.

**NOTE:** Alternately, press the right arrow key to access the options, and select an option by using the up and down arrows to highlight the option; press the left arrow key to exit the list of options.

6. Use the keyboard to enter information into fields with a blinking cursor, such as Inst. Name.



Use the Left Arrow key to exit the menu.

## SYSTEM SETUP Fields

Following is a description of the SYSTEM SETUP fields and options. Available choices are listed to the right of the field name.

**NOTE:** When applicable, the type of information and the number of characters allowed are listed in brackets to the right of the field name.

Eclipse electrocardiographs equipped with SCP-ECG capability can send and receive ECG records. The items under MANAGEMENT SYSTEM refer primarily to the use of an ECG Management System, such as the PYRAMIS System or the FAA System. The **Phone #**, **Description**, **Connection** and **Baud Rate** fields are also used when sending records between two Eclipse units. If you are using a management system, be sure to consult your System Administrator so that you can setup your Eclipse to be compatible with the management system. For more information on sending and receiving records, see “Sending and Receiving Records” on pg. 8-1.

Field Name	Options, Limitations And Description
<b>User 1-2 Select</b>	$\frac{1}{2}$ For each “User,” there is a customized group of formats. For more information on User 1 and User 2, see “Configuring the USER SETUP Menus” on pg. 4-5. <b>NOTE:</b> The unit automatically turns off and on again whenever you change the User selection. This ensures that all changes take effect.
<b>Line Filter</b>	$\frac{50}{60}$ Hz OFF Filters electrical interference from AC line voltage.
<b>Date Format</b>	$\frac{MM}{DD}$ .YY $\frac{DD}{YY}$ .MM.DD

<b>Date</b>	<p>[Up to 20 alphanumeric characters]</p> <p>Use spaces, hyphens or periods to separate the day, month and year. Some acceptable ways to type the date are:</p> <ol style="list-style-type: none"> <li>1. 10 10 1997</li> <li>2. 10-10-1997</li> <li>3. 10.10.1997</li> </ol> <p><b>NOTE:</b> Remember that the period character ( . ) is typed by holding down the Shift key and pressing the “N” key. The hyphen character ( - ) is typed by holding down the Shift key and pressing the “M” key.</p>
<b>Time</b>	<p>[Alphanumeric field displayed in 24-hour format]</p> <p>Enter hour and minutes; use a space to separate the hour from the minutes. Seconds will fill in automatically when you press Enter.</p>
<b>Language</b>	<p><u>D</u>EUTSCH  <u>E</u>SPAÑOL  <u>F</u>RANCAIS  <u>I</u>TALIANO  <u>E</u>NGLISH</p> <p>Selects language for printed and displayed text. Under normal conditions you should not have to adjust this field.</p> <p><b>NOTE:</b> The unit automatically turns off and on again whenever you change the Language selection. This ensures that all changes take effect.</p>
<b>Height Units</b>	<p><u>C</u>M.  <u>I</u>N.</p> <p>Selects units for expressing patient height.</p> <p><b>NOTE:</b> The unit automatically turns off and on again whenever you change the Units selection. This ensures that all changes take effect.</p>
<b>Weight Units</b>	<p><u>K</u>G.  <u>L</u>B.</p> <p>Selects units for expressing patient weight.</p> <p><b>NOTE:</b> The unit automatically turns off and on again whenever you change the Units selection. This ensures that all changes take effect.</p>
<b>Inst. Name</b>	<p>[Up to 30 alphanumeric characters]</p> <p>Refers to the institution. Information entered here is printed along the bottom of each printout.</p>
<b>Phone Type</b>	<p><u>T</u>OUCH TONE  <u>P</u>ULSE</p> <p><b>NOTE:</b> This field is available on Eclipse 850 units with communications and all Eclipse Plus units.</p>

<b>MANAGEMENT SYSTEM</b>	
<b>NOTE:</b> These fields are available on Eclipse 850 units with communications and all Eclipse Plus units.	
<b>Institution Number</b>	[Up to 5 numeric characters] Refers to the institution. This is extremely important when two or more institutions share a PYRAMIS System.
<b>Device Id</b>	[Up to 5 numeric characters] Identifies the Eclipse unit with a unique number. The Device Id is used by the PYRAMIS system to identify which electrocardiograph acquired each ECG record.
<b>Phone #</b>	[Up to 25 numeric characters. The comma character ( , ) inserts a pause during dialing] Provides a phone number to reach the management system or another Eclipse electrocardiograph with modem. If MODEM is selected for the <b>Connection</b> field, make sure to include a phone number to enable the sending and receiving functions on the Eclipse. Include a comma to insert a pause while dialing. A pause may be used if you need to access an "outside line." For example, this is often used after dialing a "9" prefix before the rest of the phone number.
<b>Description</b>	[Up to 20 alphanumeric characters] Identifies what management system or electrocardiograph is reached at the phone number in the above field.
<b>Connection</b>	<u>M</u> ODEM <u>D</u> IRECT <u>N</u> ONE Determines what type of connection is used when sending or receiving records. Selecting NONE disables any sending or receiving functions on the Eclipse. This will also allow the Eclipse to automatically delete records that do not have the <b>St</b> status (see "Record Status" on pg. 7-2).
<b>Baud Rate</b>	<u>2</u> 400 <u>A</u> UTO Determines the rate at which the modem will send or receive records. Selecting AUTO allows the modem to send or receive records at the fastest rate depending on the speed of the modem on the connecting equipment.
<b>AC Mains Frequency</b>	<u>U</u> NSPECIFIED <u>5</u> 0 Hz <u>6</u> 0 Hz Labels ECG records with the frequency of the AC line power which is connected to the Eclipse unit. This is used by the PYRAMIS System to identify the line frequency in the area where the records are acquired.

<b>Paper Type</b>	<u>A</u> SSURANCE 50 <u>S</u> TANDARD Sets print head resistance according to paper type selected.
<b>Analysis Statements</b>	<u>B</u> RIEF <u>F</u> ULL Selects the format of the ECG analysis statements. Selecting BRIEF will result in short, concise analysis statements with minimal explanations, presented in mixed case nomenclature for ease of reading (for example, "Normal ECG"). Selecting FULL results in lengthier analysis statements—presented in upper case nomenclature (for example, "NORMAL ECG")— and reason statements, which precede the analysis statements.
<b>Password</b>	ON OFF Determines whether a password is required to access the USER SETUP menus and the SYSTEM SETUP menu. The password is set in the MISCELLANEOUS menu (see "Password" on pg. 4-12). <b>NOTE:</b> If the password is set to OFF in SYSTEM SETUP, the password field will not appear in the MISCELLANEOUS menu.

## Verify calendar & clock settings



To verify the date and time, press the On/Standby key to put the unit in Standby mode. Then press the On/Standby key again to turn the unit on.

Check the date and time on the POWER-UP screen.

## Configuring the USER SETUP Menus

There are 7 USER SETUP menus. Use these to format printouts and reports; customize lead groups; customize demographic information in the EDIT ID menu and on printouts; set default values for Recorder Speed, Gain and Frequency Response; get Custom Header information (Eclipse w/SCP-ECG capability only); and configure miscellaneous settings.

All USER SETUP settings can be customized for both User 1 and User 2 (for more information, see "User 1-2 Select" on pg. 4-2).

**NOTE:** Default settings for Eclipse 850 and Eclipse Plus are given on pages 9-3 and 9-4.

## Go to the USER SETUP menus



1. Press the On/Standby key to power up to the PREVIEW screen.
2. Select the set of formats you want to edit by holding down the Shift key and simultaneously pressing either the “1” key or “2” key (for User 1 or User 2, respectively).

**NOTE:** The unit automatically turns off and on again whenever you change the User selection.

3. Press the “M” key to go to the MAIN MENU.
4. In the MAIN MENU, select the desired USER SETUP menu by pressing the appropriate “hot” key; for example, to select POWER-UP DEFAULTS select the “O” key.

**NOTE:** Alternately, use the up and down arrows to scroll to and select the menu. Press the enter key.

5. The new menu will appear (see Figure 4-2).

*Figure 4-2*  
A USER SETUP Menu –  
The POWER-UP  
DEFAULTS Menu

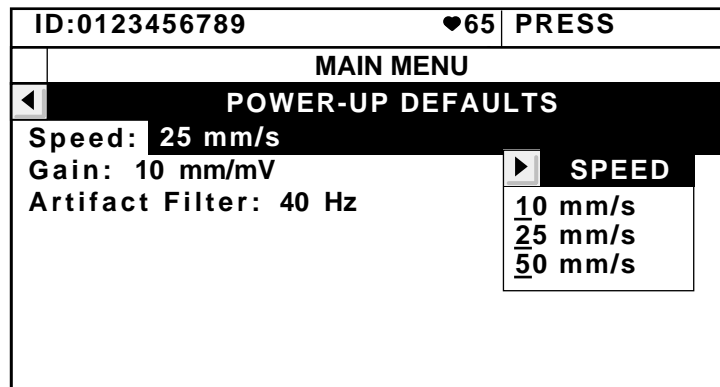

6. Use the up and down arrow keys to scroll through the fields in the selected menu. As you scroll through the fields, the options available for each field will be displayed when the field is highlighted.
7. Once a field is highlighted, change the current selection by pressing the “hot” key associated with the option. For example, to select a speed of 50 mm/s in the POWER-UP DEFAULTS MENU, press the “5” key.

**NOTE:** Alternately, press the right arrow key to access the options, and select an option by using the up and down arrows to highlight the option; press the left arrow key to exit the list of options.

8. Use the keyboard to enter information into fields with a blinking cursor.



Use the Left Arrow key to exit the menu.

## USER SETUP Menus, Fields and Options

Following are descriptions of each USER SETUP menu, with information on menu fields and options. For each field in a menu, the available choices are listed to the right of the field name. When applicable, the type of information and the number of characters allowed are listed in brackets to the right of the field name.

### POWER-UP DEFAULTS

The fields in this menu affect paper speed and waveform printing. The settings in this menu are in effect whenever the Eclipse is powered on with the On/Standby key. When changes are made in the POWER-UP DEFAULTS menu, changes go into effect the next time the Eclipse is powered on.

**NOTE:** These settings also can be temporarily modified by pressing the “7,” “8” and “9” machine control keys to change the settings for Speed, Gain, and Filter, respectively (see “The Keyboard” on pg. 3-1). Changes remain in effect until the unit powers down.

<b>Speed</b>	<u>10</u> mm/s <u>25</u> mm/s <u>50</u> mm/s Refers to chart paper speed.
<b>Gain</b>	<u>5</u> mm/mV <u>10</u> mm/mV <u>20</u> mm/mV <u>L</u> =10 <u>C</u> =5 L=20 <u>C</u> =10 Determines the amplitude of printed and displayed waveforms.
<b>Artifact Filter</b>	<u>150</u> Hz <u>40</u> Hz Sets the upper frequency response. Selecting 150 Hz provides the highest fidelity recording and should be used when little or no noise is present. The American Heart Association’s 1990 Recommendations (Recommendations for Standardization and Specifications in Automated Electrocardiography: Bandwidth and Signal Processing) pertaining to high-frequency response for both adult and pediatric recordings are met or exceeded when using the 150 Hz setting. Selecting 40 Hz will reduce the muscle tremor and patient movement artifacts in the ECG recording. It will result in a smoother looking trace at the expense of losing some of the fine detail. This filter is applied only to the printed report and displayed ECG. The data analyzed by the measurement and interpretation software is not affected when using the 40 Hz setting.

## AUTO ECG SETUP

**NOTE:** The ANALYSIS-ORIGINAL and ANALYSIS COPIES fields are available only on units with interpretive capabilities. The MEDIAN COMPLEX PAGE is available on all units with measurement capabilities.

<b>12 Lead Format</b>	<p>STANDARD, <u>4</u> CHANNEL (3 channel ECG with 1 rhythm lead)                  STANDARD, <u>3</u> CHANNEL                  STANDARD, 3 CH. + 3 (3 channel ECG with 3 rhythm leads)                  STANDARD, 6 CH 5S/LD (5 seconds per lead, 1 page total)                  STANDARD, 6 CH 10S/LD (10 seconds per lead, 2 pages total)                  CABRERA, 4 CHANNEL                  CABRERA, 3 CHANNEL                  CABRERA, 3 CH. + 3 (3 channel ECG with 3 rhythm leads)                  CABRERA, <u>6</u> CH 5S/LD (5 seconds per lead, 1 page total)                  CABRERA, <u>6</u> CH 10S/LD (10 seconds per lead, 2 pages total)</p> <p>Sets printout format. For sample printouts, see Chapter 9.</p> <p><b>NOTE:</b> If you select a 4-channel or a 3-channel plus 3 rhythm format, select a lead or leads for the rhythm printout.</p>
<b>Rhythm Leads ch. 1</b>	<p>LEAD <u>I</u>                  LEAD <u>II</u>                  LEAD <u>III</u>                  a<u>V</u>R                  a<u>V</u>L                  a<u>V</u>F                  V<u>1</u>                  V<u>2</u>                  V<u>3</u>                  V<u>4</u>                  V<u>5</u>                  V<u>6</u>                  -a<u>V</u>R</p> <p>Selects leads used if an ECG with rhythm lead(s) is selected for <b>12 Lead Format</b> above.</p>
<b>Rhythm Leads ch. 2</b>	Same as Channel 1
<b>Rhythm Leads ch. 3</b>	Same as Channel 1
<b>Rhythm Page</b>	<p>CUSTOM LEAD 1 AT <u>25</u> mm/s                  CUSTOM LEAD 1 AT <u>50</u> mm/s                  OFF</p> <p>Enables a separate 10-second rhythm report as part of every Auto ECG report. This is not available if Custom Lead 1 is set to Frank or Nehb.</p>
<b>Analysis-original</b>	<p>ON                  OFF</p> <p>Determines whether analysis statements appear on Auto ECG reports.</p>

<b>Analysis-copies</b>	<p>ON OFF</p> <p>Determines whether analysis statements appear on copies of Auto ECG reports.</p>
<b>Number Of Copies</b>	<p>[Numeric. Range = 0-5]</p> <p>Sets the number of complete report copies to print in addition to the automatic printout.</p>
<b>Median Complex Page</b>	<p>ON OFF</p> <p>Enables Median Complex printout as part of every Auto ECG report.</p>
<b>Print Mode</b>	<p>AUTO MANUAL OFF</p> <p>Determines how ECG reports are printed. If AUTO is selected, then reports automatically print out prior to saving. If OFF is selected, no report is printed prior to saving. If MANUAL is selected, then prior to saving the unit will display a message asking whether to print the record.</p>
<b>Save Mode</b>	<p>AUTO AUTO SAVE AND SEND MANUAL</p> <p>Determines how Auto ECG reports are saved. If AUTO is selected, reports will be automatically saved after printing. If MANUAL save is selected, the PREVIEW screen is displayed at the end of every Auto ECG sequence. You may save the report at this time. If AUTO SAVE AND SEND is selected, then the report is automatically saved; the report is also sent automatically to an ECG Management System, such as the PYRAMIS System or the FAA System.</p>
<b>Wait for good data</b>	<p>ON OFF</p> <p>When ON, Auto ECG reports are delayed until ten seconds of low noise waveform have been collected (all electrodes must be connected). An immediate report can be forced by pressing ECG a second time. In this case, the report will state "Warning: Data quality may affect computer interpretation."</p> <p>When OFF, the Auto ECG report starts once at least 10 seconds of ECG waveform has been collected, regardless of the quality of the collected waveform data. No warning message is printed in this case.</p> <p><b>NOTE:</b> If any electrodes are disconnected the report will show a flat baseline for those leads. ("Overload" conditions will also produce a flat baseline.) Leads with disconnected electrodes will not be used in the ECG analysis.</p>

## CUSTOM LEAD 1 & CUSTOM LEAD 2

These two menus each format a group of leads. These groups can later be selected by pressing the "5" or "6" machine control keys (see "The Keyboard" on pg. 3-1).

Custom Lead Group 1 is also used for the rhythm page of an Auto ECG report. Only Standard or Cabrera configurations are acceptable for this purpose. Do not select Frank or Nehb if you want a rhythm page as part of an Auto ECG.

**NOTICE:** Because the Eclipse offers different lead configurations, always ensure that the appropriate lead placement is employed for the lead configuration selected.

**Custom Lead 1  
(Eclipse 850)**

STANDARD, 3 CHANNEL  
 STANDARD, 6 CHANNEL  
 STANDARD, 12 CHANNEL  
 CABRERA, 3 CHANNEL  
 CABRERA, 6 CHANNEL  
 CABRERA, 12 CHANNEL  
 ALTERNATE CHEST LEAD (3X4, 1R)  
 FRANK, 3 CHANNEL  
 NEHB, 3 CHANNEL

Format Custom Lead 1 to suit your needs.

If you have selected 3 channel, 6 channel or Alternate Chest Lead, you will need to select leads for the appropriate channels. Lead availability is affected by the selected lead configuration.

**Custom Lead 1  
(Eclipse Plus)**

STANDARD, 3 CHANNEL (3x1)  
 STANDARD, 6 CHANNEL (6x1)  
 STANDARD, 12 CHANNEL (3x4)  
 STANDARD, 12 CHANNEL (3x4, 1R)  
 STANDARD, 12 CHANNEL (3x4, 3R)  
 STANDARD, 12 CHANNEL (6x2)  
 CABRERA, 3 CHANNEL (3x1)  
 CABRERA, 6 CHANNEL (6x1)  
 CABRERA, 12 CHANNEL (3x4)  
 CABRERA, 12 CHANNEL (3x4, 1R)  
 CABRERA, 12 CHANNEL (3x4, 3R)  
 CABRERA, 12 CHANNEL (6x2)  
 ALTERNATE CHEST LEAD (3X4, 1R)  
 FRANK, 3 CHANNEL (3x1)  
 NEHB, 3 CHANNEL (3x1)

Format Custom Lead 1 to suit your needs. The numbers in parentheses indicate how the selected lead group will be displayed on the screen. If you select a display that includes rhythm leads, the rhythm leads displayed are the same ones that have been selected for printing in the Auto ECG Setup menu. (See "AUTO ECG SETUP" on pg. 4-8.)

If you have selected Alternate Chest Lead or a non-12 lead Standard or Cabrera format, select leads for the appropriate channels. Lead availability is affected by the selected lead configuration.

**Channel 1 through  
Channel 6**

When programming Custom Lead 1, select 1 lead for each channel. The lead options for each format are listed below.

**NOTE:** Lead availability is affected by the selected lead configuration.

<u>Standard</u>	<u>Cabrera</u>	<u>Frank</u>
LEAD I	LEAD I	X
LEAD II	LEAD II	Y
LEAD III	LEAD III	Z
aVR	-aVR	
aVL	aVL	<b>Nehb</b>
aVF	aVF	D
V1	V1	A
V2	V2	J
V3	V3	
V4	V4	
V5	V5	
V6	V6	
-aVR	aVR	

**Channel 7 through  
Channel 12**

When programming Custom Lead 1 or Custom Lead 2 for Alternate Chest Leads, select one of the following options for each of the channels (Channel 7 through Channel 12).

- V1
- V2
- V3
- V4
- V5
- V6
- V7
- V8
- V9
- V1R
- V2R
- V3R
- V4R
- V5R
- V6R
- V7R
- V8R
- V9R

**Custom Lead 2**

Custom Lead Group 2 is similar to Custom Lead Group 1. It is set up in the same manner. It is then accessed by pressing the number "6" on the keyboard.

## MISCELLANEOUS SETTINGS

<b>Baseline Filter</b>	<p>0.05 Hz STABLE</p> <p>Sets the low frequency response.</p> <p>Selecting 0.05 Hz provides the greatest low-frequency response with no delay and should be used when no baseline drift is present.</p> <p>Selecting STABLE (Baseline Stabilization Filter) will effectively suppress most baseline wander interference while providing an accurate ECG reproduction (no distortion of the ST segment.) Use of the Baseline Stabilization Filter will result in an approximately 1.5 second delay in the displayed ECG. This filter is applied to the printed report, displayed ECG, and the data analyzed.</p> <p><b>NOTE:</b> The American Heart Association's 1990 Recommendations (Recommendations for Standardization and Specifications in Automated Electrocardiography: Bandwidth and Signal Processing) pertaining to low-frequency response in electrocardiography are met or exceeded by both the 0.05 Hz and STABLE selections.</p>
<b>Pacer Enhancement</b>	<p>ON OFF</p> <p>Enables pacemaker enhancement. This feature makes pacemaker signals show up as prominent spikes on the display and on printouts. An enhanced pacer is printed as a spike that is at least 10 mm tall and of positive polarity.</p>
<b>Rhythm Mode Pages</b>	<p>[Numeric. Range = 1-10]</p> <p>Sets the number of pages printed during an Auto Rhythm.</p>
<b>Bradycardia Limit</b>	<p>[Numeric. Range = 41-69]</p> <p>Reports for adult patients with heart rates below this limit are labelled "BRADYCARDIA." For more information on heart rate limits refer to the Physician's Guide.</p> <p><b>NOTE:</b> This feature is available on interpretive units only.</p>
<b>Tachycardia Limit</b>	<p>[Numeric. Range = 81-129]</p> <p>Reports for adult patients with heart rates above this limit are labelled "TACHYCARDIA." For more information on heart rate limits refer to the Physician's Guide.</p> <p><b>NOTE:</b> This feature is available on interpretive units only.</p>
<b>Password</b>	<p>[Up to 15 alphanumeric characters]</p> <p><b>NOTE:</b> The password field will not appear in the MISCELLANEOUS menu if the password is set to OFF in SYSTEM SETUP.</p> <p><b>NOTE:</b> Write down the password and keep it in a secure place. You will be able to change or remove the password protection only after you have entered the correct password.</p> <p>Determines the password required to access the USER SETUP menus and the SYSTEM SETUP menu. You can set a different password for both User 1 and User 2. This field is enabled in the SYSTEM SETUP menu [see "Password" on pg. 4-5].</p>

**Auto Print Received ECGs**

ON  
OFF

When ON, unit automatically prints each ECG as it is received when in the RECEIVE ECGS mode (see "Sending and Receiving records from an Eclipse" on pg. 8-6).

### ENABLING PATIENT DEMOGRAPHIC FIELDS

**NOTE:** This menu will not be available if the Eclipse is configured to use Custom Header in conjunction with an ECG Management System, such as the PYRAMIS System or the FAA System.

This final USER SETUP menu determines which patient demographic fields appear in the EDIT ID menu. An asterisk ( \* ) indicates that information in these fields directly affects ECG waveform analysis.

To ensure that a field does NOT appear in the EDIT ID menu, the field setting should be "OFF". Otherwise, select "ON," "ON, CLEAR" or "ON, HOLD" to make each demographic field appear in the EDIT ID menu; these fields also appear on printouts.

- Select "ON, HOLD" if you want every patient file to have the same information in this field. Until the information is typed over, the EDIT ID menu will keep the information in these fields even if the Eclipse is turned off. For example, you may want every patient record to be labeled with the same Department name.
- "ON" and "ON, CLEAR" act the same. Fields with this setting are cleared for every new patient or when the unit returns to Standby mode.

<b>*V3 Placement</b>	<p><u>ON, CLEAR</u> <u>ON, HOLD</u> <u>OFF</u></p> <p>Used for pediatric recording of V4R only.</p>
<b>Last Name</b>	<p><u>ON</u> <u>OFF</u></p>
<b>First Name</b>	<p><u>ON</u> <u>OFF</u></p>
<b>*D.O.B.</b>	<p><u>ON</u> <u>OFF</u></p>
<b>*Age</b>	<p><u>ON</u> <u>OFF</u></p>
<b>*Age Format</b>	<p><u>ON</u> <u>OFF</u></p>
<b>*Sex</b>	<p><u>ON</u> <u>OFF</u></p>

<b>*Race</b>	ON OFF
<b>*Medication 1</b>	ON OFF
<b>*Medication 2</b>	ON OFF
<b>* Class 1</b>	ON OFF
<b>* Class 2</b>	ON OFF
<b>Height</b>	ON OFF
<b>Weight</b>	ON OFF
<b>Systolic BP</b>	ON OFF
<b>Diastolic BP</b>	ON OFF
<b>Department</b>	ON, CLEAR ON, HOLD OFF
<b>Room</b>	ON, CLEAR ON, HOLD OFF
<b>Technician</b>	ON, CLEAR ON, HOLD OFF
<b>Physician</b>	ON, CLEAR ON, HOLD OFF
<b>User Field</b>	ON, CLEAR ON, HOLD OFF
<b>User Field Label</b>	[Up to 15 alphanumeric characters] Renames the above field. The new name is displayed in the EDIT ID menu and printed on patient demographics reports. The User Field may be used for anything. For example, you may want to use the field for the referring physician's name.
<b>Comments</b>	ON OFF

## GETTING CUSTOM HEADER INFORMATION (ECLIPSE W/SCP-ECG)

The Get Custom Header function is available for Eclipse electrocardiographs that are used with an ECG Management System, such as the PYRAMIS System or the FAA System.

Custom Header information is a list of patient demographic items to be used in the EDIT ID menu and to be printed on ECG reports. This list is maintained on the ECG data management system. By connecting to the management system, the Eclipse can be programmed to use the Custom Header.

You can connect to the PYRAMIS ECG Data Management System in two ways: using a Direct Connection, or using a Remote Connection (this requires an Eclipse with either an internal or external modem).

**NOTE:** If you are using a direct connection, begin by connecting the Interconnect Cable to the connector labeled "DECG-SCP" on the PYRAMIS back panel. Connect the other end of the cable to the connector labeled "IOIO" on the Eclipse back panel.

**NOTE:** The following procedure only affects the User currently selected (either User 1 or User 2; see "User 1-2 Select" on pg. 4-2). The procedure must be repeated to get or update the custom header for the other User.



1. Press the On/Standby key to power up to the PREVIEW screen.
2. Press the "M" key to go to the MAIN MENU.
3. Select SYSTEM SETUP by pressing the "S" key. The SYSTEM SETUP menu will appear (see Figure 4-1 on pg. 4-1).
4. Press the Down Arrow key to highlight the **Connection** field and select the appropriate choice: either **DIRECT** or **MODEM**.
5. If you are using a remote connection (through a modem), verify that the **Phone #** and **Description** fields are correctly filled in.
6. Press the Left Arrow key to return to the MAIN MENU.
7. Press the "H" key to go to the GET CUSTOM HEADER menu.
8. Receive a list of available Custom Headers by selecting **GET CUSTOM HEADER LIST**.
9. Highlight the desired Custom Header and press the Enter key to select it. The word "SELECT" is displayed.

**NOTE:** Pressing Enter will also deselect a selection.

10. Press the Left Arrow key to return to the GET CUSTOM HEADER menu.



11. Press the "G" key to receive the Custom Header and automatically configure the Eclipse to use those patient demographic fields.

## Acquiring a Printout of Eclipse Program Settings

Program settings include all settings configured in the SYSTEM SETUP menu and in the USER SETUP menus.

**NOTE:** Please see "Print Setup Report" on pg. 9-2 for examples which were printed using settings configured at the factory (factory defaults).



1. Press the On/Standby key to power up to the PREVIEW screen.
2. Press the "M" key to go to the MAIN MENU.
3. Press the "P" key to print the list.



Press the Left arrow key to return to the PREVIEW screen.

## Choosing the environment



**WARNING:** *Explosion hazard. Do NOT use in the presence of flammable anesthetics.*

**CAUTION:** *Although the Eclipse is designed to meet IEC 601-1-2 EMC immunity requirements, the presence of strong EMI fields generated by electronic, surgical or diathermy instruments close to the unit, may cause trace noise or input overload conditions.*

The Eclipse is a high fidelity instrument which responds to the minute voltages of the heart. Since it is such a sensitive instrument, take care to avoid interference which can be produced by muscle tremor and AC signals. To minimize interference, locate the electrocardiograph and patient away from power cords and other electrical devices.

## Preparing Patients for Resting ECGs

To minimize muscle artifact, make sure your patient is comfortable and relaxed. Assure the patient that there is no danger or pain involved, and that his or her cooperation will assist in producing a valuable diagnostic record.

Make the patient comfortable on a cot or padded table which is large enough to support arms and legs. The patient's arms should rest at his or her sides and the legs should lie flat, not touching one another. Use a pillow to support the patient's head. Also, try to avoid factors like cold drafts which could cause discomfort. Leaving the chest and sensor sites exposed, cover your patient with a blanket to prevent shivering.

Apply sensors and connect lead wires before entering patient information into the Eclipse. This allows time for the sensors to adhere and improves conductivity.

## Preparing the Skin

Refer to the “Resting ECG Lead Placement & Coding Chart” on pg. 5-3 for details on where sensor sites are located.

**NOTE:** For information on alternate chest lead and other lead placements, see “Alternative Lead Placements” on pg. 5-7.

If the patient has oily or sweaty skin, or has recently applied lotion to their skin, clean the sensor sites with alcohol. Allow the sensor sites to dry completely before applying sensors.

When applying sensors to sites with a lot of hair, the following techniques may improve contact:

1. Use the thumb and forefinger to spread the hair before applying the sensor to the skin.
2. If the sensor does not adhere well, it may be necessary to shave the site.

**NOTE:** In some cases skin irritation can occur from site preparation and sensor electrolyte solutions.

## Applying Sensors

Apply sensors according to the instructions on the following pages. For information on using disposable sensors, see “Disposable Resting ECG Sensors” on pg. 5-4. For information on using reusable sensors, see “Reusable ECG Sensors” on pg. 5-5.

# Resting ECG Lead Placement & Coding Chart

AHA STANDARD LIMB LEADS		LEAD CODING AND MEASUREMENTS				IEC STANDARD LIMB LEADS	
LEAD	SENSORS CONNECTED / MEASURED	LEAD	LOCATION	BAND	LABEL	LEAD	SENSORS CONNECTED / MEASURED
LEAD I LEAD II LEAD III	LA-RA LL-RA LL-LA	RL	RIGHT LEG	GREEN		LEAD I LEAD II LEAD III	L-R F-R F-L
AUGMENTED LIMB LEADS		RA	RIGHT ARM	WHITE		AUGMENTED LIMB LEADS	
LEAD	SENSORS CONNECTED / MEASURED	LA	LEFT ARM	BLACK		aVR	R and (L-F)
aVR aVL aVF	RA and (LA-LL) LA and (RA-LL) LL and (RA-LA)	V <sub>1</sub>	CHEST	BROWN	RED	aVL	L and (R-F)
		V <sub>2</sub>	CHEST	BROWN	YELLOW	aVF	F and (R-L)
		V <sub>3</sub>	CHEST	BROWN	GREEN	CHEST LEADS	
		V <sub>4</sub>	CHEST	BROWN	BLUE	LEAD	SENSORS CONNECTED / MEASURED
		V <sub>5</sub>	CHEST	BROWN	ORANGE	C <sub>1</sub>	C <sub>1</sub> and (L-R-F)
		V <sub>6</sub>	CHEST	BROWN	VIOLET	C <sub>2</sub>	C <sub>2</sub> and (L-R-F)
CHEST LEADS						C <sub>3</sub>	C <sub>3</sub> and (L-R-F)
LEAD	SENSORS CONNECTED / MEASURED					C <sub>4</sub>	C <sub>4</sub> and (L-R-F)
V <sub>1</sub> V <sub>2</sub> V <sub>3</sub> V <sub>4</sub> V <sub>5</sub> V <sub>6</sub>	V <sub>1</sub> and (LA-RA-LL) V <sub>2</sub> and (LA-RA-LL) V <sub>3</sub> and (LA-RA-LL) V <sub>4</sub> and (LA-RA-LL) V <sub>5</sub> and (LA-RA-LL) V <sub>6</sub> and (LA-RA-LL)					C <sub>5</sub>	C <sub>5</sub> and (L-R-F)
AHA COLOR CODE						C <sub>6</sub>	C <sub>6</sub> and (L-R-F)
LEAD	LOCATION	BAND	LABEL				
IEC COLOR CODE							
LEAD	LOCATION	BAND	LABEL				

### PLACEMENT OF THE CHEST SENSORS

#### AHA

**V<sub>1</sub>** Fourth intercostal space at right margin of sternum

**V<sub>2</sub>** Fourth intercostal space at left margin of sternum

**V<sub>4</sub>** Fifth intercostal space at junction of left midclavicular line

**V<sub>3</sub>** Midway between position V<sub>2</sub> and position V<sub>4</sub>

**V<sub>5</sub>** At horizontal level of position V<sub>4</sub> at left anterior axillary line

**V<sub>6</sub>** At horizontal level of position V<sub>4</sub> at left midaxillary line

---

#### IEC

**C<sub>1</sub>** Fourth intercostal space at right margin of sternum

**C<sub>2</sub>** Fourth intercostal space at left margin of sternum

**C<sub>4</sub>** Fifth intercostal space at junction of left midclavicular line

**C<sub>3</sub>** Midway between position C<sub>2</sub> and position C<sub>4</sub>

**C<sub>5</sub>** At horizontal level of position C<sub>4</sub> at left anterior axillary line

**C<sub>6</sub>** At horizontal level of position C<sub>4</sub> at left midaxillary line

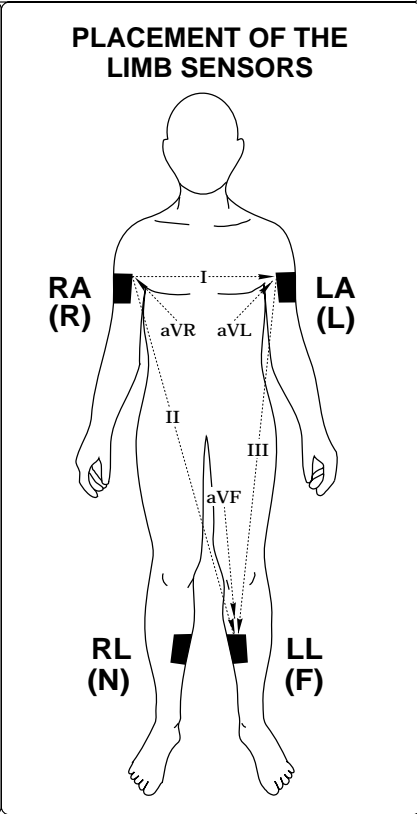

## Disposable Resting ECG Sensors

Spacelabs Burdick CardioSens<sup>®</sup> disposable sensors are a more effective alternative to bulbs, plates, straps, creams, and gels. CardioSens<sup>®</sup> disposable sensors dramatically reduce cross-contamination and infection, while helping to improve diagnostic results.

Disposable sensors should be stored according to the guidelines on the packaging and should not be used after the expiration date. Never mix sensor types or brands. Incompatibilities can cause baseline drift and can increase trace recovery time after defibrillation.

### APPLYING LIMB SENSORS

1. Expose the arms and legs.
2. Place sensors firmly on the limb sites. Choose fleshy areas, not ankles or wrists (see Figure 5-1).
3. Clip leads to the sensors. Leads on arm sensors should point downward toward feet. Leads on legs should point upward toward chest.

**Figure 5-1**  
*Disposable Limb Sensor on Arm*

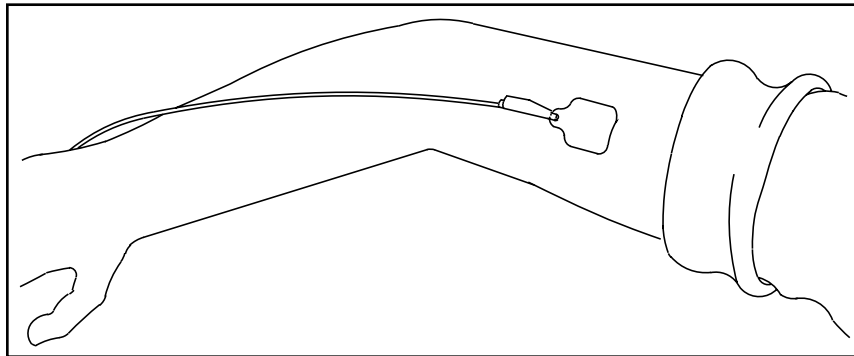

### APPLYING CHEST SENSORS

1. Expose the chest.
2. Locate the 6 V-lead (C-lead) positions on the patient's chest.
3. Apply the sensors.
4. Ensure that the leads conform to body contours and that no strain is placed on the sensors.

## Reusable ECG Sensors

Never mix sensor types or brands. Dissimilar metals or other incompatibilities may cause considerable baseline drift and may increase trace recovery time after defibrillation. Do not use corroded sensors, they may give poor results.

### ELECTROLYTE

**NOTE:** Watches and jewelry which could come in contact with electrolyte should be removed to avoid damage.

Spacelabs Burdick recommends Liqui-cor® for use with reusable sensors. Liqui-cor® provides excellent conductivity between the skin and sensor. In addition, it is nonabrasive and water soluble for easy cleanup.

Reusable sensors (Welsh bulbs and limb plates) should be kept clean. They should be washed after each use and scoured frequently with a light-duty kitchen cleanser. Never use a metallic pad to clean the sensors. Accumulation of electrolyte may cause drifting and degrade ECG quality.

### APPLYING LIMB PLATES

1. Expose the arms and legs.
2. Connect sensor straps to the “ears” of the sensors.

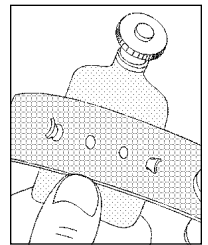

3. Squeeze out a small amount of Spacelabs Burdick Liqui-cor® on sensor as illustrated. Spread it evenly over the sensor surface. Always apply the same amount of electrolyte to each sensor.

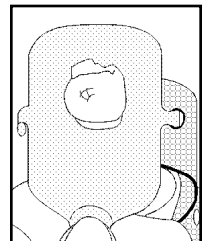

4. Place sensors firmly on the limb sites. Position them so that the sensor will not press against the body or table when the patient is relaxed. On arms, the screws should point downward toward the feet. On legs, the screws should point upward, toward chest.
5. Without stretching the strap, wrap it around the limb until a hole lines up with a sensor “ear.” Then stretch the strap and fasten it with the next hole.
6. Connect the limb leads to the four sensors.

## APPLYING WELSH BULB CHEST SENSORS

1. Connect the 6 Welsh bulb sensors to the V-leads (C-leads) on the patient cable.
2. Locate the 6 V-lead (C-lead) positions on the patient's chest (see "Resting ECG Lead Placement & Coding Chart" on pg. 5-3).
3. Squeeze out a drop of Liqui-cor® electrolyte at each sensor site. Use a tongue depressor to spread the electrolyte taking care that it does not touch the electrolyte from another site.
4. Apply the sensors by squeezing the rubber bulb and allowing suction to hold the sensor in place. Only a small dimple should remain on the bulb when it is released.
5. Ensure that the leads conform to the body contours and that no strain is placed on the sensors.

## Connecting Cables and Lead Wires

After applying sensors, connect the lead wires from the patient cable to the sensors. Make sure the lead cables follow the contours of the patient's body and lie flat. If any lead wire is too long, as with a short patient or child, take up the length by making a small "stress loop" (see Figure 5-2).

*Figure 5-2*  
*Lead Cable Arrangement*

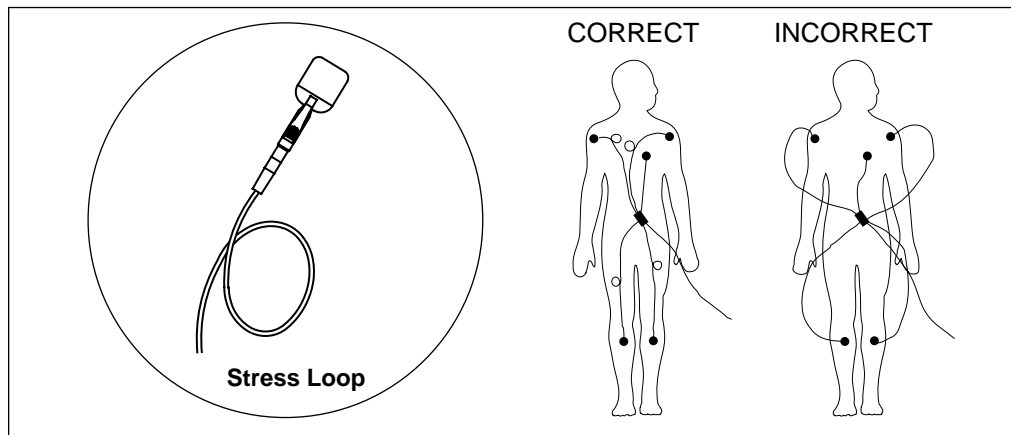

Make sure the patient cable is plugged securely into the connector on the front of the unit. This is located under the keyboard (see "Connecting the Patient Cable" on pg. 2-3).

## Alternative Lead Placements

### Pediatric Lead Placement

When acquiring a pediatric ECG, you may use an alternative to the standard V<sub>3</sub> (C<sub>3</sub>) placement. Place the sensor in the V<sub>4R</sub> (C<sub>4R</sub>) position. This is across the sternum from V<sub>4</sub> (C<sub>4</sub>). See Figure 5-3 for location. Improper placement will result in inaccurate waveform labelling.

You must select the corrected V<sub>3</sub> (C<sub>3</sub>) placement in the EDIT ID menu (see "Entering Patient Demographics" on pg. 6-9). If you place V<sub>3</sub> (C<sub>3</sub>) in the V<sub>4R</sub> (C<sub>4R</sub>) position, select "V4R" in the \*V3 Placement field located in the EDIT ID menu for proper printout labelling.

*Figure 5-3*  
Pediatric Chest Lead  
Placement

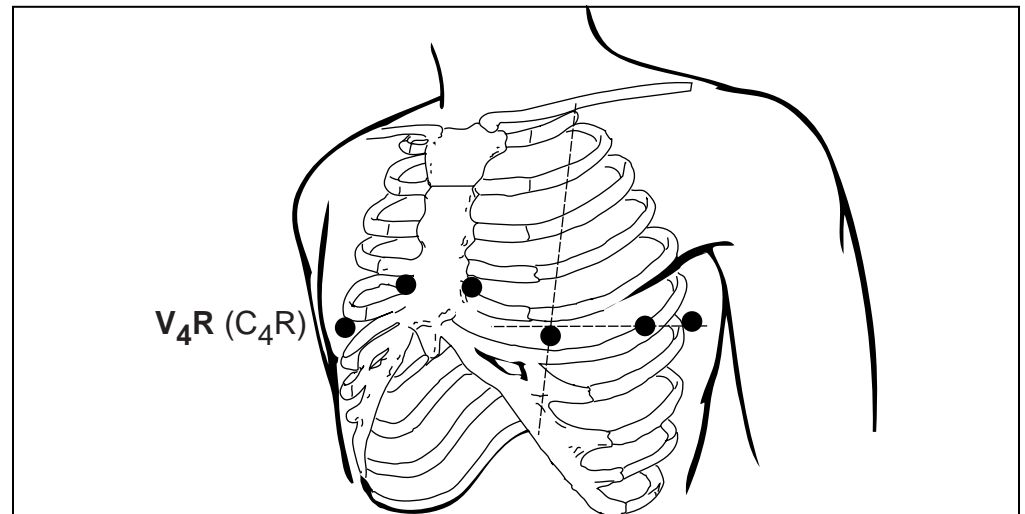

### Frank: Corrected Orthogonal Leads

Attach all the limb sensors, R, L, F, and N (RA, LA, LL and RL). Please see "Resting ECG Lead Placement & Coding Chart" on pg. 5-3 for diagram.

Attach the chest sensors according to the following table. I, E, C, M and A should all be in the same horizontal plane level with the fifth intercostal space (see Figure 5-4).

V <sub>1</sub> (C <sub>1</sub> )	Chest - right midaxillary line	I
V <sub>2</sub> (C <sub>2</sub> )	Chest - midsternum	E
V <sub>3</sub> (C <sub>3</sub> )	Chest - midclavicular line	C
V <sub>4</sub> (C <sub>4</sub> )	Chest - left midaxillary line	A
V <sub>5</sub> (C <sub>5</sub> )	Back - spine, opposite E	M
V <sub>6</sub> (C <sub>6</sub> )	Throat or back of neck	H

Figure 5-4  
Frank Lead Placement

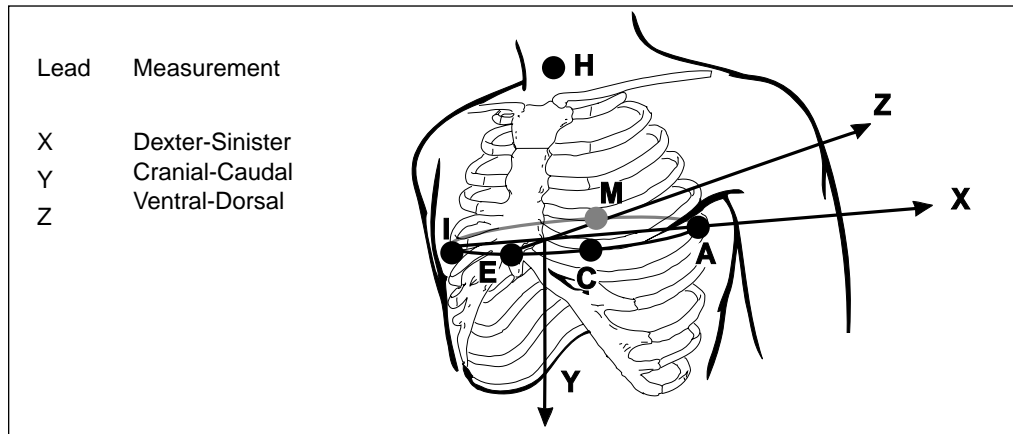

### Nehb: Bipolar Leads

Attach all the limb sensors, RA, LA, LL and RL (R, L, N, and F). Please see "Resting ECG Lead Placement & Coding Chart" on pg. 5-3 for diagram.

Attach the chest sensors according to the following table (see Figure 5-5).

$V_1$ ( $C_1$ )	Chest - second rib at right sternal border	$N_{st}$
$V_2$ ( $C_2$ )	Back - left posterior axillary line on level with the bottom tip of the scapula.	$N_{ax}$
$V_3$ ( $C_3$ )	Chest - opposite the scapular apex at the same level as $V_2$ above.	$N_{ap}$

Figure 5-5  
Nehb Lead Placement

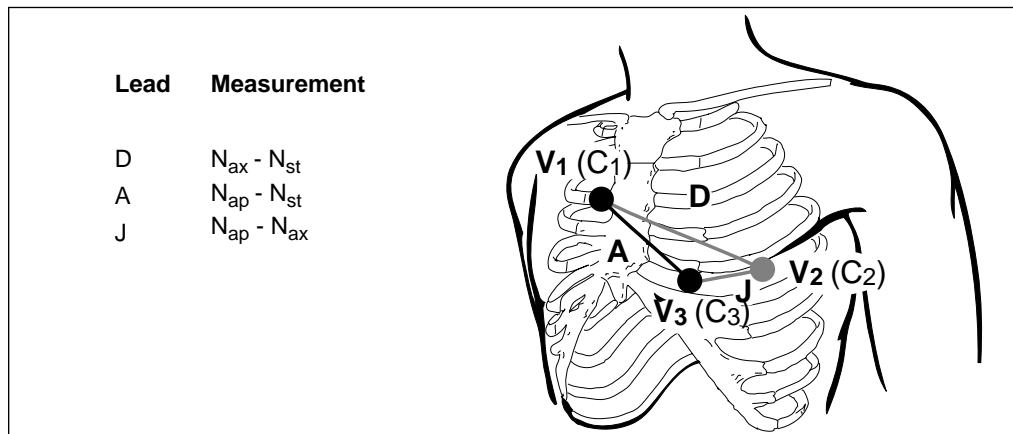

## Alternate Chest Lead

Acquire a standard 12-lead ECG according to the “Resting ECG Lead Placement & Coding Chart” on pg. 5-3.

For the Alternate Chest Lead ECG, retain the placement of the limb sensors. Reposition the chest sensors using 6 of the placements described in the table below. Configure leads as desired. See the table below for a sample lead configuration.

**NOTE:** The lead configuration for the Alternate Chest Lead is completely customizable. The example below is only one of many possible lead configurations.

**NOTE:** Lead configuration may also contain any of the standard chest leads, if desired.

Lead	Alternate Placement	Description
	V <sub>2</sub> R (C <sub>2</sub> R) position	fourth intercostal space at right margin of sternum
	V <sub>3</sub> R (C <sub>3</sub> R) position	midway between position V <sub>2</sub> R (C <sub>2</sub> R) and position V <sub>4</sub> R (C <sub>4</sub> R)
V <sub>1</sub> (C <sub>1</sub> )	V <sub>4</sub> R (C <sub>4</sub> R) position	fifth intercostal space at junction of right midclavicular line
V <sub>2</sub> (C <sub>2</sub> )	V <sub>5</sub> R (C <sub>5</sub> R) position on right	horizontal level with V <sub>4</sub> R (C <sub>4</sub> R) at right anterior axillary line
V <sub>3</sub> (C <sub>3</sub> )	V <sub>6</sub> R (C <sub>6</sub> R) position on right	horizontal level with V <sub>4</sub> R (C <sub>4</sub> R) and V <sub>5</sub> R (C <sub>5</sub> R) at right midaxillary line
V <sub>4</sub> (C <sub>4</sub> )	V <sub>7</sub> (C <sub>7</sub> ) position	horizontal level with V <sub>6</sub> (C <sub>6</sub> ) at posterior axillary line
V <sub>5</sub> (C <sub>5</sub> )	V <sub>8</sub> (C <sub>8</sub> ) position	horizontal level with V <sub>6</sub> (C <sub>6</sub> ) and V <sub>7</sub> (C <sub>7</sub> ) at mid scapular line
V <sub>6</sub> (C <sub>6</sub> )	V <sub>9</sub> (C <sub>9</sub> ) position	horizontal level with V <sub>7</sub> (C <sub>7</sub> ) and V <sub>8</sub> (C <sub>8</sub> ) next to spinal column
	V <sub>7</sub> R (C <sub>7</sub> R) position	horizontal level with V <sub>6</sub> R (C <sub>6</sub> R) at posterior axillary line
	V <sub>8</sub> R (C <sub>8</sub> R) position	horizontal level with V <sub>6</sub> R (C <sub>6</sub> R) and V <sub>7</sub> R (C <sub>7</sub> R) at mid scapular line
	V <sub>9</sub> R (C <sub>9</sub> R) position	horizontal level with V <sub>7</sub> R (C <sub>7</sub> R) and V <sub>8</sub> R (C <sub>8</sub> R) next to spinal column

Figure 5-6  
Placement Options

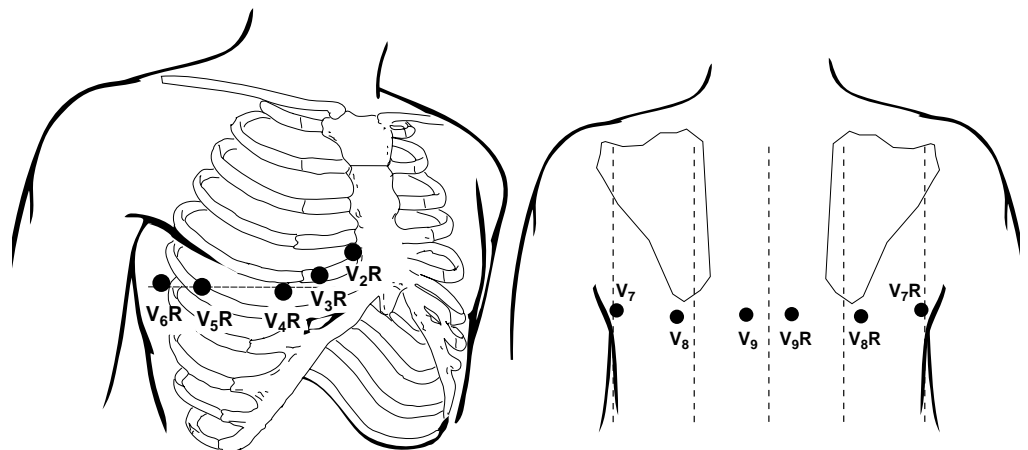

## Preparing Patients for Exercise Stress Testing

Apply electrodes and lead wires before entering patient data into the Eclipse. This allows time for the electrodes to adhere and improves conductivity.

1. Place limb leads where movement is not a factor (see Figure 5-7).
2. Vigorous skin preparation is essential for preventing artifact during exercise stress testing:
  - ✓ Shave all hair from sensor sites
  - ✓ Cleanse sensor sites with alcohol
  - ✓ Use a Skin Rasp. Applying moderate pressure, stroke the skin 2 or 3 times at each site with the rough side of the rasp.
3. As you apply sensors, press down on the outside foam area first to avoid squeezing the gel out.
4. After applying the sensors, follow the instructions on page 5-6, "Connecting Cables and Lead Wires".

Figure 5-7  
Exercise Stress Lead  
Placement

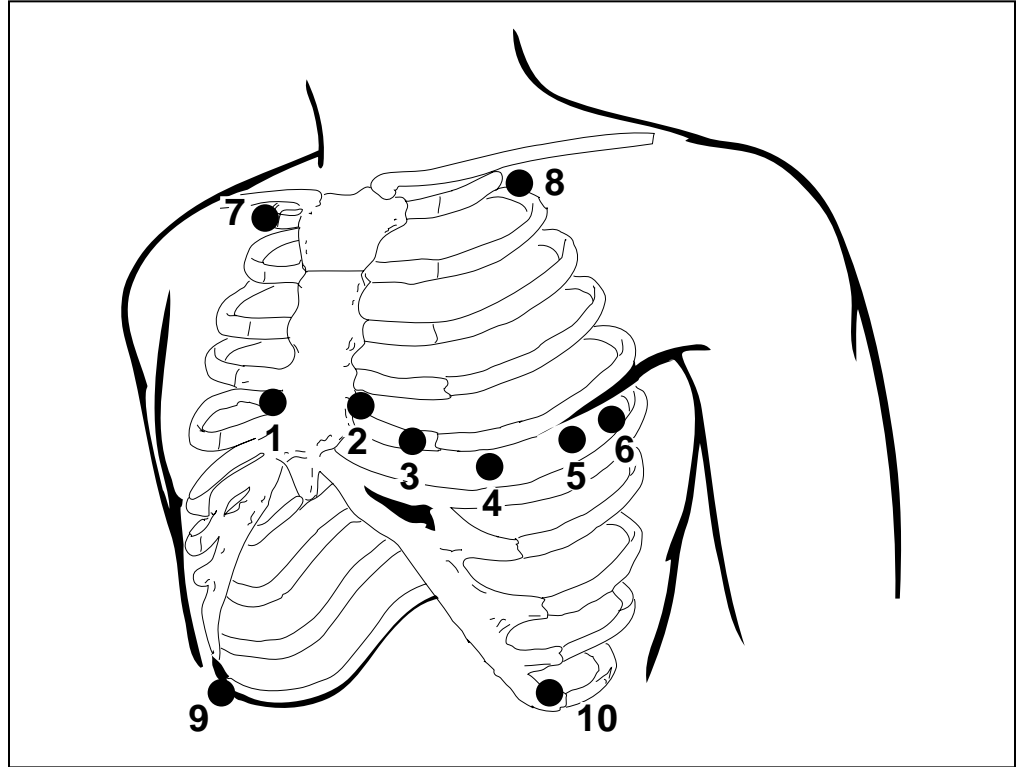

Key			
	AHA	IEC	
1	V <sub>1</sub>	C <sub>1</sub>	Fourth intercostal space at right margin of sternum.
2	V <sub>2</sub>	C <sub>2</sub>	Fourth intercostal space at left margin of sternum.
3	V <sub>3</sub>	C <sub>3</sub>	Midway between 2 and 4.
4	V <sub>4</sub>	C <sub>4</sub>	Fifth intercostal space at junction of left midclavicular line.
5	V <sub>5</sub>	C <sub>5</sub>	At horizontal level of position V4 at left anterior axillary line.
6	V <sub>6</sub>	C <sub>6</sub>	At horizontal level of position V4 at left midaxillary line.
7	RA	R	Beneath clavicle.
8	LA	L	Beneath clavicle.
9	RL	N	In line with 7.
10	LL	F	In line with 8 and 4.



Acquiring and printing ECG reports with an Eclipse Plus or an Eclipse 850 is quite simple. Once the patient is hooked up to the Eclipse, an ECG can be acquired at any time by pressing the  button.



It is a good idea to enter patient demographic information before performing tests. However, patient demographic information also may be entered after the tests have been completed.

**NOTE:** Some patient information directly affects ECG analysis. Your patient's physician uses this information when interpreting ECG reports. Likewise, interpretive Eclipse units provide more accurate and complete analysis statements when you enter patient information thoroughly. This information must be entered prior to acquiring the ECG in order to affect the interpretation.

## Acquiring a Stat ECG

Sometimes it will be necessary to take an ECG and there will not be time to enter any patient demographic information. If no patient ID is entered, Eclipse units with storage will print "#STAT#" in the **Patient ID** field, followed by the date and time.

**NOTE:** Some patient information directly affects ECG analysis. Your patient's physician uses this information when interpreting ECG reports. Likewise, interpretive Eclipse units provide more accurate and complete analysis statements when you enter patient information thoroughly. This information must be entered prior to acquiring the ECG in order to affect the interpretation.

1. Prepare patient according to guidelines in Chapter 5, "Patient Preparation."
2. From Standby mode, press  to power up to the PREVIEW screen.
3. Verify that the "Sensors OK" message is displayed on the PREVIEW screen.
4. Press the "ECG" function key  to acquire an Auto ECG report.



**NOTE:** This key is active in the PREVIEW screen and most menus, including the EDIT ID menu.

## Acquiring an Auto ECG

**NOTE:** Some patient information directly affects ECG analysis. Your patient's physician uses this information when interpreting ECG reports. Likewise, interpretive Eclipse units provide more accurate and complete analysis statements when you enter patient information thoroughly. This information must be entered prior to acquiring the ECG in order to affect the interpretation.



**NOTE:** Press the "STOP" function key at any time to halt an Auto ECG.

1. Prepare the patient according to guidelines in Chapter 5, "Patient Preparation."
2. From Standby mode, press  to power up to the PREVIEW screen.
3. If a file already exists for the patient (a requisition exists for the patient or demographic information has been entered previously), go to "Acquiring an ECG Using an Existing Patient File" on pg. 6-3.
4. Press  to go to the EDIT ID menu. Enter the patient's ID number, last name, first name, date of birth, sex, and as many other fields as required or as time will allow (for more information, see "Patient Demographic Fields" on pg. 6-10).

**NOTE:** Items indicated with an asterisk (\*) may affect computer analysis.

5. Press the left arrow key  to return to the PREVIEW screen. Verify that the "Sensors OK" message is displayed on the PREVIEW screen.

**NOTE:** The Recorder Speed, Gain and Frequency Response settings (displayed in the lower right corner of the PREVIEW screen) can be temporarily modified if necessary. See "Temporarily Changing Current Settings" on pg. 6-5.

6. Press  to acquire an Auto ECG.

**NOTE:** To obtain a clean trace with very little noise, ensure that **Wait for Good Data** is set to ON in the AUTO ECG SETUP menu. If there is a problem during a recording, the Eclipse will display a message. You can override the error message and continue recording by pressing the ECG key again (for more information, see “Wait for good data” on pg. 4-9).

7. Depending on the current system settings, Eclipse will automatically print and save the ECG. (If the unit is equipped with communication capabilities, the ECG might also be automatically sent, depending on the settings.) Otherwise, a prompt may be displayed on the screen, asking if you wish to print or save the ECG.

**NOTE:** To view or modify the print or save settings, see “Print Mode” and “Save Mode” on pg. 4-9.

8. If you have saved the ECG, then the Single ECG Functions list is displayed. At this time you may perform additional functions with the saved test (see “Accessing Saved Files” on pg. 7-3).



Use the Left Arrow key to exit.

## Acquiring an ECG Using an Existing Patient File

If a requisition has been downloaded for a patient, then a demographics-only file will already exist for the patient (see “Receiving requisitions from PYRAMIS” on pg. 8-4). It is also possible to create a demographics-only file for a patient, separately from when the patient’s ECG is acquired (see “Add New Patient” on pg. 7-6). Once a demographics-only file exists for a patient, acquiring the ECG is simple.

**NOTE:** The following procedure also applies if the patient’s ECG has been acquired in the past and the test still exists in the system.

1. From the PREVIEW screen, press the “M” key to view the MAIN MENU.
2. Press the “D” key to advance to the DIRECTORY menu.
3. Press the “N” key to view all existing files by name (VIEW BY NAME), or press the “I” key to VIEW BY ID (on the Eclipse Plus, select VIEW DIRECTORY). Select the patient’s file from those listed.
4. Press the “A” key to Acquire ECG. The EDIT ID menu is displayed. Make changes to patient information if necessary.
5. Press the left arrow key  to return to the PREVIEW screen. Verify that the “Sensors OK” message is displayed on the PREVIEW screen.

**NOTE:** The Recorder Speed, Gain and Frequency Response settings (displayed in the lower right corner of the PREVIEW screen) can be temporarily modified if necessary. See “Temporarily Changing Current Settings” on pg. 6-5.

6. Press  to acquire an Auto ECG.

**NOTE:** To obtain a clean trace with very little noise, ensure that **Wait for Good Data** is set to ON in the AUTO ECG SETUP menu. If there is a problem during a recording, the Eclipse will display a message. You can override the error message and continue recording by pressing the ECG key again (for more information, see “Wait for good data” on pg. 4-9).

7. Depending on the current system settings, Eclipse will automatically print and save the ECG. (If the unit is equipped with communication capabilities, the ECG might also be automatically sent, depending on the settings.) Otherwise, a prompt may be displayed on the screen, asking if you wish to print or save the ECG.

**NOTE:** To view or modify the print or save settings, see “Print Mode” and “Save Mode” on pg. 4-9.

8. If you have saved the ECG, then the Single ECG Functions list is displayed. At this time you may perform additional functions with the saved test (see “Accessing Saved Files” on pg. 7-3).

 Use the Left Arrow key to exit.

## Printing Reports

**NOTE:** You can immediately terminate any printout by pressing the “STOP” key. The Eclipse advances the chart paper to the next page and returns to the PREVIEW screen.

A formatted, 12-lead report with demographics is automatically included in any ECG printout. The following reports may also be included with the printout, depending upon system settings: a rhythm report, a median report, and an analysis report.

For more information on selecting the rhythm report and the median report, see “AUTO ECG SETUP” on pg. 4-8. Analysis information will be included on the printout for interpretive units only, unless this feature has been disabled (see “Analysis-original” on pg. 4-8).

## Printing Problems

If the unit runs out of paper or if the paper jams, you are given the option to reload the paper and continue printing (see Figure 6-1). Alternatively, you may stop the function and return to the PREVIEW screen. For paper loading instructions see “Loading Recording Paper” on pg. 2-6.

*Figure 6-1  
System Note Regarding a  
Printing Problem*

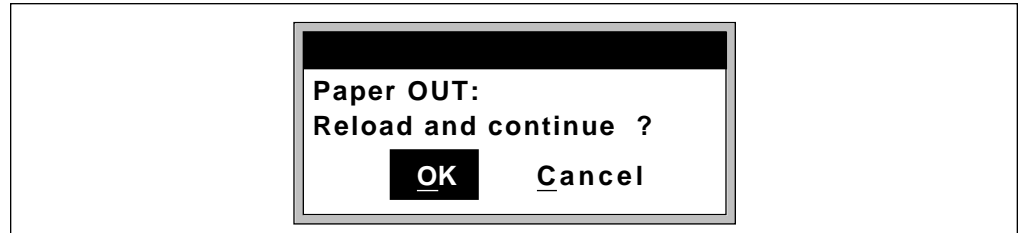

## Temporarily Changing Current Settings

Occasionally it may be necessary to modify the system settings for the current patient. There are several settings that you can customize before acquiring a patient’s ECG. If you wish to change the below settings permanently, see “POWER-UP DEFAULTS” on pg. 4-7.

### Recorder Speed, Gain, Frequency Response

Use machine control keys “7” through “9” to adjust Recorder Speed, Gain or Frequency Response.



The “7” key toggles the Paper Speed between 10, 25 and 50 mm/sec.



The “8” key toggles the ECG Gain between 5 mm/mV, 10 mm/mV, 20 mm/mV, L10,C5 mm/mV and L20, C10 mm/mV.



The “9” key toggles the ECG Filter Frequency between 40 and 150 Hz.

**NOTE:** Settings are displayed in the lower right corner of the PREVIEW screen. These settings will stay in effect until you change them or return the unit to Standby mode.

## Acquiring an Auto Rhythm or a Manual Rhythm

**NOTE:** REDUCED PERFORMANCE MODE. Printing performance of an Auto Rhythm or a Manual Rhythm may be reduced when the current Custom Lead format is Frank and when the printing speed is set to 50 mm/s.

**NOTE:** It is not possible to save Auto Rhythm or Manual Rhythm data.

The Eclipse can be set up to automatically print a rhythm page with the 12-lead ECG. If this feature is not selected, or if an additional rhythm strip is required, you can obtain a rhythm strip by simply pressing the “RHYT” function key or the “MAN” function key.

1. Follow the directions for acquiring a STAT ECG or an AUTO ECG, as described earlier in this chapter (see page 6-1).

**NOTE:** The Recorder Speed, Gain and Frequency Response settings (displayed in the lower right corner of the PREVIEW screen) can be temporarily modified if necessary. See “Temporarily Changing Current Settings” on pg. 6-5.

2. The Eclipse prints the rhythm report using the channels displayed in the PREVIEW screen. Before printing, select the desired leads using the machine control keys “1” through “6.”
3. To print a rhythm strip for a predefined number of pages, press the “RHYT” function key .

**NOTE:** The rhythm strip will print for the number of pages defined in the MISCELLANEOUS menu (see “Rhythm Mode Pages” on pg. 4-12).

4. Press the “MAN” function key  to acquire a manual rhythm strip. **In the Manual Rhythm mode, the Eclipse will continue to print the rhythm strip until either the “STOP” function key or another function key is pressed.**

**NOTE:** While printing, you may place a 1 mV simulated calibration pulse  on the printout and display by pressing the “0” key.

5. To cancel printing at any time for either selection, Press the “STOP” function key . You may also interrupt printing and begin another report by pressing any of the other function keys to the left of the keyboard.

## Acquiring an ECG Using Alternative Lead Placements

At times it may be necessary to acquire an ECG using an alternative lead placement. The Alternate Chest Lead ECG allows acquisition of right chest leads and expanded left chest leads. Other alternative lead placements include Frank and Nehb.

**NOTE:** The standard ECG is an important part of the Alternate Chest Lead ECG. If you are acquiring an Alternate Chest Lead ECG, run a standard resting ECG before continuing (for more information, see “Acquiring an Auto ECG” on pg. 6-2).

1. Configure either the CUSTOM LEAD 1 or CUSTOM LEAD 2 for the desired lead placement (see “CUSTOM LEAD 1 & CUSTOM LEAD 2” on pg. 4-9).
2. Follow the directions for acquiring a STAT ECG or an AUTO ECG, as described earlier in this chapter (see page 6-1).
3. From the Single ECG Functions List, press the left arrow key  to return to the PREVIEW screen.
4. Prepare the patient for the Alternate Chest Lead ECG according to guidelines in Chapter 5 (see “Alternate Chest Lead” on pg. 5-9). Attach electrodes according to the specific instructions for each lead configuration.
5. Verify patient ID on screen. If patient ID is incorrect or absent, follow steps 1 through 3 of “Acquiring an ECG Using an Existing Patient File” on pg. 6-3.
6. Select “5” or “6” from the keyboard, depending on whether the alternative placement was selected for CUSTOM LEAD 1 or CUSTOM LEAD 2.



**NOTE:** If ALTERNATE CHEST LEAD was selected, the screen should display **Alternate Chest Lead ECG**. In addition, the statement “Alternate Chest Lead ECG” will appear on the printout in place of the interpretation.

7. Verify waveforms before taking the ECG.

**NOTE:** The Recorder Speed, Gain and Frequency Response settings (displayed in the lower right corner of the PREVIEW screen) can be temporarily modified if necessary. See “Temporarily Changing Current Settings” on pg. 6-5.



8. Press the “ECG” function key to record the ECG.

Eclipse automatically prints the ECG.

## Acquiring an ECG Using Pediatric Lead Placements

**NOTE:** The Eclipse unit can be set up to always acquire ECGs using pediatric lead placement. Refer to “\*V3 Placement” in “Enabling Patient Demographic Fields” on pg. 4-13.

1. Prepare the patient according to guidelines in Chapter 5, “Patient Preparation.” Attach electrodes according to the specific instructions for “Pediatric Lead Placement” on pg. 5-7.
2. Follow steps 2, 3 and 4 of “Acquiring an Auto ECG” on pg. 6-2. **At the top of the EDIT ID screen, for V3 Placement, select V4R.**

**NOTE:** In the EDIT ID menu, change the Age Format to months and enter the patient’s age in months, if desired.

3. Press the left arrow key  to return to the PREVIEW screen. Verify waveforms before taking the ECG.

**NOTE:** The Recorder Speed, Gain and Frequency Response settings (displayed in the lower right corner of the PREVIEW screen) can be temporarily modified if necessary. See “Temporarily Changing Current Settings” on pg. 6-5.

4. Press  to acquire an Auto ECG.

**NOTE:** To obtain a clean trace with very little noise, ensure that **Wait for Good Data** is set to ON in the AUTO ECG SETUP menu. If there is a problem during a recording, the Eclipse will display a message. You can override the error message and continue recording by pressing the ECG key again (for more information, see “Wait for good data” on pg. 4-9).

5. Depending on the current system settings, Eclipse will automatically print and save the ECG. (If the unit is equipped with communication capabilities, the ECG might also be automatically sent, depending on the settings.) Otherwise, a prompt may be displayed on the screen, asking if you wish to print or save the ECG.

**NOTE:** To view or modify the print or save settings, see “Print Mode” and “Save Mode” on pg. 4-9.

6. If you have saved the ECG, then the Single ECG Functions list is displayed. At this time you may perform additional functions with the saved test (see “Accessing Saved Files” on pg. 7-3).



Use the Left Arrow key to exit.

---

---

## Entering Patient Demographics

**NOTE:** Some patient information directly affects ECG analysis. Your patient's physician uses this information when interpreting ECG reports. Likewise, interpretive Eclipse units provide more accurate and complete analysis statements when you enter patient information thoroughly. This information must be entered prior to acquiring the ECG in order to affect the interpretation.

### About Patient Demographics

Before acquiring a patient's ECG, it is a good idea to enter patient information, since this information affects both physician analysis and computer analysis. On the Eclipse 850 and the Eclipse Plus, fields which directly affect computer analysis, such as the \***D.O.B.** (date of birth) field, are marked with an asterisk (\*). In addition, patient information is used to label all ECG reports until you begin a new patient file or return the unit to Standby mode.

### Using the EDIT ID Menu



Patient information is entered using the EDIT ID menu. The EDIT ID menu can be accessed from several different locations. To access the EDIT ID menu from either the PREVIEW screen or the MAIN MENU, press the "I" key (you may also use the arrow up and arrow down keys in the MAIN menu to select ENTER ID; press ENTER). The EDIT ID menu will be displayed.

**NOTE:** If you want to create a file for this patient in the Directory, select **ADD NEW PATIENT** in the DIRECTORY menu (see "Using the DIRECTORY Menu" on pg. 7-1).

**NOTE:** You may exit the EDIT ID menu at any time by pressing the Left arrow key.

If demographics have been entered already, a message appears which reads, "**NEW Patient?**". Selecting **YES** begins a new file. Selecting **NO** uses the current patient information.

Figure 6-2  
The EDIT ID Menu

ID:0123456789		♥65	PRESS
◀ EDIT ID			
(*Items may affect computer analysis)			
*V3 Placement	:	STANDARD	▲
Patient ID	:	123456789	
Last Name	:		
First Name	:		
*D.O.B.	:		
*Age	:		
*Age Format	:	YEA	
*Sex	:		
*Medication 1	:		
*Class 1	:		
Comments	:		

**NEW Patient?**

## Patient Demographic Fields

Scroll through the EDIT ID menu fields using the up and down arrows.

In most fields in the EDIT ID menu, the cursor blinks. In these fields, type the appropriate information from the keyboard. In this chapter, the type of information and the number of characters allowed are listed in brackets next to the field name. Press the ENTER key to enter the information.

Other fields in the EDIT ID menu have lists. Select the appropriate item from a list by pressing the hot key indicated by the underlined letter. Or, press the right arrow key to access the options, use the up and down arrow keys to select an option, and press the ENTER key to enter the option. In this chapter, the available choices are listed next to the field name.

**NOTE:** Some of the fields described here may not appear because they have been disabled in the PATIENT FIELDS ENABLE menu (see “Enabling Patient Demographic Fields” on pg. 4-13) or because the Eclipse is configured to use a Custom Header (see “Getting Custom Header Information (Eclipse w/SCP-ECG)” on pg. 4-15).

The EDIT ID fields are described below.

**NOTE:** Fields which directly affect computer analysis are marked with an asterisk ( \* ).

<b>*V3 Placement</b>	<p>STANDARD V4R</p> <p>Use only for pediatric reports. For more information on pediatric lead placement, see “Pediatric Lead Placement” on pg. 5-7.</p>
<b>Patient ID</b>	[Up to 20 alphanumeric characters]
<b>Last Name</b>	[Up to 20 alphanumeric characters]

<b>First Name</b>	[Up to 20 alphanumeric characters]	
<b>*D.O.B (Date Of Birth)</b>	<p>[Up to 20 alphanumeric characters]</p> <p>Use spaces, hyphens or periods to separate the day, month and year. Some acceptable ways to type the date are:</p> <ol style="list-style-type: none"> <li>1. 10 10 1950</li> <li>2. 10-10-1950</li> <li>3. 10.10.1950</li> </ol> <p><b>NOTE:</b> Remember that the period character ( . ) is typed by holding down the Shift key and pressing the “N” key. The hyphen character ( - ) is typed by holding down the Shift key and pressing the “M” key.</p> <p><b>*D.O.B.</b> is used to automatically fill in <b>*Age</b> and <b>*Age Format</b>. For accuracy and convenience, you may wish to use this field rather than fill in <b>*Age</b> manually.</p>	
<b>*Age</b>	<p>[Up to 3 numeric characters. Range = 0-364]</p> <p>Not editable if <b>*D.O.B.</b> was entered.</p>	
<b>*Age Format</b>	<p><u>Y</u>EAR<u>S</u>  <u>M</u>ON<u>T</u>H<u>S</u>  <u>D</u>A<u>Y</u><u>S</u></p> <p>Not editable if <b>*D.O.B.</b> was entered.</p>	
<b>*Sex</b>	<p><u>b</u>l<u>a</u>n<u>k</u>  <u>M</u>A<u>L</u>E  <u>F</u>E<u>M</u>A<u>L</u>E</p>	
<b>*Race</b>	<p><u>b</u>l<u>a</u>n<u>k</u>  <u>B</u>L<u>A</u>C<u>K</u>  <u>C</u>A<u>U</u>C<u>A</u>S<u>I</u>A<u>N</u>  <u>O</u>R<u>I</u>E<u>N</u>T<u>A</u>L  <u>O</u>T<u>H</u>E<u>R</u> R<u>A</u>C<u>E</u>  <u>U</u>N<u>K</u>N<u>O</u>W<u>N</u></p>	
<b>*Medication 1</b>	<p><u>b</u>l<u>a</u>n<u>k</u>  <u>N</u>O M<u>E</u>D<u>I</u>C<u>A</u>T<u>I</u>O<u>N</u>  <u>U</u>N<u>K</u>N<u>O</u>W<u>N</u>  <u>D</u>I<u>G</u>I<u>T</u>A<u>L</u>I<u>S</u>  <u>D</u>I<u>U</u>R<u>E</u>T<u>I</u>C  <u>B</u>E<u>T</u>A B<u>L</u>O<u>C</u>K<u>E</u>R  <u>Q</u>I<u>N</u>I<u>D</u>I<u>N</u>E  <u>P</u>R<u>O</u>C<u>A</u>I<u>N</u>A<u>M</u>I<u>D</u>E  <u>A</u>M<u>I</u>O<u>D</u>A<u>R</u>O<u>N</u>E  <u>D</u>I<u>S</u>O<u>P</u>Y<u>R</u>A<u>M</u>I<u>D</u>E</p>	<p><u>L</u>I<u>D</u>O<u>C</u>A<u>I</u>N<u>E</u>  <u>O</u>T<u>H</u>E<u>R</u> A<u>N</u>T<u>I</u>A<u>R</u>R<u>H</u>Y<u>T</u>H<u>M</u>I<u>C</u>  <u>P</u>S<u>Y</u>C<u>H</u>O<u>T</u>R<u>O</u>P<u>I</u>C  <u>S</u>T<u>E</u>R<u>O</u>I<u>D</u>  <u>C</u>A<u>L</u>C<u>I</u>U<u>M</u> B<u>L</u>O<u>C</u>K<u>E</u>R<u>S</u>  <u>N</u>I<u>T</u>R<u>A</u>T<u>E</u>S  <u>A</u>C<u>E</u> I<u>N</u>H<u>I</u>B<u>I</u>T<u>O</u>R<u>S</u>  <u>A</u>L<u>P</u>H<u>A</u> B<u>L</u>O<u>C</u>K<u>E</u>R<u>S</u>  <u>O</u>T<u>H</u>E<u>R</u> M<u>E</u>D<u>I</u>C<u>A</u>T<u>I</u>O<u>N</u></p>
	<p>Select a medication type if you know the category of medication your patient is taking. For ECG waveform analysis, it is better to select <u>N</u>O M<u>E</u>D<u>I</u>C<u>A</u>T<u>I</u>O<u>N</u> or <u>U</u>N<u>K</u>N<u>O</u>W<u>N</u> than to leave this field blank.</p>	

<b>*Medication 2</b>	<p>See <b>*MEDICATION 1</b>, above</p> <p><b>NOTE:</b> If you typically use just the <b>*Medication 1</b> and <b>*Class 1</b> fields, use the PATIENT FIELDS ENABLE menu to select the <b>OFF</b> setting for the <b>*Medication 2</b> and <b>*Class 2</b> fields (see “Enabling Patient Demographic Fields” on pg. 4-13).</p> <p><b>NOTE:</b> Do not use this field if blank, <u>NO</u> MEDICATION or <u>UNKNOWN</u> is selected for <b>*Medication 1</b>. These entries for <b>*Medication 1</b> cause the analysis program in interpretive Eclipse units to ignore the <b>*Medication 2</b> field.</p>																
<b>*Class 1</b>	<table border="0"> <tr> <td>blank</td> <td>PERICARDITIS</td> </tr> <tr> <td><u>N</u>ORMAL</td> <td><u>R</u>ESPIRATORY DISEASE</td> </tr> <tr> <td><u>U</u>NKNOWN</td> <td><u>I</u>MPLANTED PACER</td> </tr> <tr> <td><u>M</u>YOCARDIAL INFARCTION</td> <td><u>E</u>NDOCRINE DISEASE</td> </tr> <tr> <td><u>M</u>YOCARDIAL ISCHEMIA</td> <td><u>P</u>ULMONARY EMBOLISM</td> </tr> <tr> <td><u>H</u>YPERTENSION</td> <td><u>P</u>OST CARDIAC SURGERY</td> </tr> <tr> <td><u>C</u>ONGENITAL HEART DISEASE</td> <td><u>C</u>ARDIOMYOPHY</td> </tr> <tr> <td><u>R</u>HEUMATIC HEART DISEASE</td> <td><u>O</u>TH<u>E</u>R</td> </tr> </table> <p>Refers to the patient's cardiac, lung, or endocrine conditions. Select the appropriate diagnosis from the list if you know your patient's condition. For ECG waveform analysis, it is better to select <u>N</u>ORMAL or <u>U</u>NKNOWN than to leave this field blank.</p>	blank	PERICARDITIS	<u>N</u> ORMAL	<u>R</u> ESPIRATORY DISEASE	<u>U</u> NKNOWN	<u>I</u> MPLANTED PACER	<u>M</u> YOCARDIAL INFARCTION	<u>E</u> NDOCRINE DISEASE	<u>M</u> YOCARDIAL ISCHEMIA	<u>P</u> ULMONARY EMBOLISM	<u>H</u> YPERTENSION	<u>P</u> OST CARDIAC SURGERY	<u>C</u> ONGENITAL HEART DISEASE	<u>C</u> ARDIOMYOPHY	<u>R</u> HEUMATIC HEART DISEASE	<u>O</u> TH <u>E</u> R
blank	PERICARDITIS																
<u>N</u> ORMAL	<u>R</u> ESPIRATORY DISEASE																
<u>U</u> NKNOWN	<u>I</u> MPLANTED PACER																
<u>M</u> YOCARDIAL INFARCTION	<u>E</u> NDOCRINE DISEASE																
<u>M</u> YOCARDIAL ISCHEMIA	<u>P</u> ULMONARY EMBOLISM																
<u>H</u> YPERTENSION	<u>P</u> OST CARDIAC SURGERY																
<u>C</u> ONGENITAL HEART DISEASE	<u>C</u> ARDIOMYOPHY																
<u>R</u> HEUMATIC HEART DISEASE	<u>O</u> TH <u>E</u> R																
<b>*Class 2</b>	<p>See <b>*CLASS 1</b>, above</p> <p><b>NOTE:</b> If you typically use just the <b>*Medication 1</b> and <b>*Class 1</b> fields, use the PATIENT FIELDS ENABLE menu to select the <b>OFF</b> setting for the <b>*Medication 2</b> and <b>*Class 2</b> fields (see “Enabling Patient Demographic Fields” on pg. 4-13).</p> <p><b>NOTE:</b> Do not use this field if blank, <u>N</u>ORMAL or <u>U</u>NKNOWN is selected for <b>*Class 1</b>. These entries for <b>*Class 1</b> cause the analysis program in interpretive Eclipse units to ignore the <b>*Class 2</b> field.</p>																
<b>Height</b>	<p>[Up to 3 numeric characters. Range = 0-96 in. or 0-244 cm.] Measured in either inches or centimeters as determined in the SYSTEM SETUP menu.</p>																
<b>Weight</b>	<p>[Up to 3 numeric characters. Range = 0- 500 lb. or 0-227 kg.] Measured in either pounds or kilograms as determined in the SYSTEM SETUP menu.</p>																
<b>Systolic BP (Blood Pressure)</b>	<p>[Up to 3 numeric characters. Range = 0 – 250]</p>																
<b>Diastolic BP (Blood Pressure)</b>	<p>[Up to 3 numeric characters. Range = 0 – 250]</p>																
<b>Department</b>	<p>[Up to 5 numeric characters. Range 1 – 32000] Identifies your department in the facility. A list of the allowable selections is displayed if it has been downloaded from PYRAMIS. To download ECGs from PYRAMIS, the department must be entered with the correct number or set to 1 on the Eclipse 850 or Plus.</p>																
<b>Room</b>	<p>[Up to 7 alphanumeric characters] Identifies your location within the facility.</p>																

<b>Technician</b>	[Up to 20 alphanumeric characters] Identifies the person acquiring the ECG.
<b>Physician</b>	[Up to 20 alphanumeric characters] Identifies the patient's physician.
<b>User Field</b>	[Up to 15 alphanumeric characters] Use this field to suit your needs. A possible use might be to identify the referring physician. You may label this field in the USER SETUP menu (see "Configuring the USER SETUP Menus" on pg. 4-5).
<b>Comments</b>	[Up to 120 alphanumeric characters] Use this field to input additional patient information as needed.



Once a patient's record has been saved, it is possible to reprint, delete and transmit ECG records, as well as edit patient information. It is also possible to create files for one or more patients prior to acquiring any ECGs.

**NOTE:** Speed, gain and/or artifact filter can be changed prior to reprinting a record. See "Printing ECG Reports" on pg. 7-4.

## Using the DIRECTORY Menu

In order to perform any of the functions described above, it is necessary to access the DIRECTORY menu.



1. Press the On/Standby key to power up to the PREVIEW screen.
2. Press the "M" key to go to the MAIN MENU.
3. Press the "D" key to go to the DIRECTORY menu (see Figure 7-1).

*Figure 7-1*  
The DIRECTORY Menu

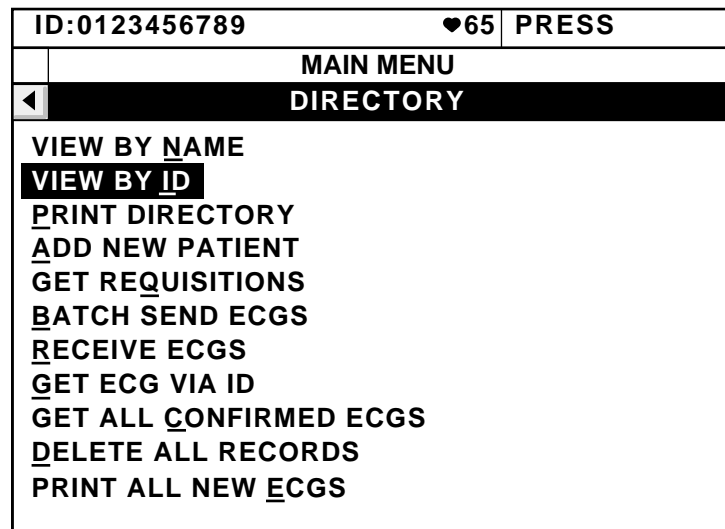

4. To view patient records, scroll to and select the **VIEW BY NAME** or **VIEW BY ID** field by pressing either the "N" key or the "I" key (on the Eclipse Plus, select **VIEW DIRECTORY**).
5. A list of all records stored in the directory is displayed.

## Record Status

The status of each record is indicated in the last column of the directory contents.

The status of a record is important, especially when transmitting and receiving records from another electrocardiograph or ECG management system (for more information, see “How record status affects the sending operations” on pg. 8-1). Record status also can affect which records are retained in the event that the directory is full (see “Automatic deletion when the Directory is full” on pg. 7-3).

Use the table below to understand the record status associated with each code.

Code	Record Status	Explanation of Status
<b>Pr</b>	Printed	The Auto ECG record has been printed by the Eclipse electrocardiograph.
<b>Dm</b>	Demographics Only	The record contains only patient demographic information. The record does not contain an ECG report.
<b>St</b>	Sent	The record has been sent to another electrocardiograph or to an ECG Management System, such as the PYRAMIS System or the FAA System.
<b>No</b>	Do Not Send	The record was manually marked so that the record will not be sent the next time that <b>BATCH SEND ECGS</b> is selected in the DIRECTORY menu.
<b>Rv</b>	Received	The record was received from another electrocardiograph or from an ECG Management System, such as the PYRAMIS System or the FAA System.
<b>Rq</b>	Requisition	The record contains only patient demographic information. An ECG report is being requested for this patient by the ECG data management system.
<b>ECG</b>	12-Lead	The record contains a 12-lead ECG.
<b>RtE</b>	Alternate Chest Lead	The record contains an Alternate Chest Lead (non-standard) ECG.

On Eclipse Plus and Eclipse 850 units with communications, it is possible to change the status of certain records. With this feature, users can ensure that certain records are sent and other records are not sent when BATCH SEND ECGS is selected in the DIRECTORY menu (for more information, see “Changing Record Status” on pg. 8-1).

---

---

## Automatic deletion when the Directory is full

If you create a new record when the Directory is full, the Eclipse deletes an older record to make room for the new record. There are rules based on record status which determine which records are automatically deleted. The oldest record with the proper status is deleted.

- Records with status **Dm** or **Rq** are never deleted. However, a record with both **Rq** and **St** will be deleted.
- If, in the SYSTEM SETUP menu, the **Connection** field is set to **MODEM** or **DIRECT**, a record with status **Pr** and **St** may be deleted.
- If, in the SYSTEM SETUP menu, the **Connection** field is set to **MODEM** or **DIRECT**, a record with status **Rv** and **Pr** may be deleted.
- If, in the SYSTEM SETUP menu, the **Connection** field is set to **NONE**, any record with status **Pr** may be deleted.

If the Directory is full of records that don't meet any of the automatic deletion criteria, you will not be able to create new records unless you manually delete records from the Directory (the **Directory Full** message is displayed). You may, however, obtain Auto ECG printouts. These will not be stored in the Directory unless storage space is made available.

## Accessing Saved Files

### Editing Patient Demographics

1. In the DIRECTORY menu, scroll to and select the **VIEW BY NAME** or **VIEW BY ID** field by pressing either the "N" key or the "I" key (on the Eclipse Plus, select **VIEW DIRECTORY**).
2. Locate the desired patient file, highlight it and press the Enter key. The Single ECG Functions list is displayed.
3. Press the "E" key to access the EDIT ID menu.
4. Edit patient demographics as desired. These changes are saved when you press the Left Arrow key to exit this menu.

**NOTE:** Patient ID, date of birth, age, and age format cannot be changed.

## Printing ECG Reports

1. In the DIRECTORY menu, scroll to and select the **VIEW BY NAME** or **VIEW BY ID** field by pressing either the "N" key or the "I" key (on the Eclipse Plus, select **VIEW DIRECTORY**).
2. Locate the desired patient file, highlight it, and press the Enter key. The Single ECG Functions list is displayed.
3. If you wish to edit patient information, press the "E" key to access the EDIT ID menu. Make changes as desired. Press the left arrow to return to the Single ECG Functions list.
4. If you wish to modify the settings for Recorder Speed, Gain or Frequency Response, press the "C" key to access the CHANGE SPEED, GAIN, FILTER menu. Use the arrows to make different selections. Press the left arrow to return to the Single ECG Functions list.
5. Press the "P" key to print a copy of the report.

**NOTE:** Depending upon system settings, the ECG report will include a rhythm report and a median complex report. Analysis information may also be included on the printout for interpretive units only, unless this feature has been disabled. To verify or change the print settings, see "Rhythm Page", "Median Complex Page", and "Analysis-original" on pg. 4-8.

6. Manually print a copy of the median complex report for the record by pressing the "R" key.

**NOTE:** Chart speed is fixed at 50 mm/s.

7. Print a copy of the measurement matrix for the record by pressing the "N" key.



Use the Left Arrow key to exit.

---

---

## Deleting Patient Files

**NOTE:** This procedure permanently removes the selected record.

1. In the DIRECTORY menu, scroll to and select the **VIEW BY NAME** or **VIEW BY ID** field by pressing either the "N" key or the "I" key (on the Eclipse Plus, select **VIEW DIRECTORY**).
2. Locate the desired patient file, highlight it and press the Enter key. The Single ECG Functions list is displayed.
3. Select **DELETE ECG** by pressing the "D" key to permanently delete the file.
4. A message box will appear. Press the "O" key to confirm deletion.



**NOTE:** Proceed with caution; choosing Ok will permanently erase the record. To cancel the request, select Cancel.



Use the Left Arrow key to exit.

## Faxing Saved Files

**NOTE:** To use the Fax function, your Eclipse must be equipped with either an internal or an external modem.

1. In the DIRECTORY menu, scroll to and select the **VIEW BY NAME** or **VIEW BY ID** field by pressing either the "N" key or the "I" key (on the Eclipse Plus, select **VIEW DIRECTORY**).
2. Locate the desired patient file, highlight it and press the Enter key. The Single ECG Functions list is displayed.
3. Press the "F" key to access the FAX ECG menu.
4. Select the destination for the fax by pressing the corresponding hot key: "1," "2," "3" or "4." Eclipse faxes the report.

**NOTE:** See "Configuring the FAX Menu" on pg. 7-7 to edit fax numbers and information.



Use the Left Arrow key to exit.

## Additional Functions

### Add New Patient

If you wish to create one or more patient files prior to recording any ECGs, use the ADD NEW PATIENT selection in the DIRECTORY. This feature allows you to input demographics into the Directory in advance of taking an ECG, which later reduces the time required to acquire the report.

1. In the DIRECTORY menu, select the ADD NEW PATIENT field by pressing the “A” key.
2. The EDIT ID menu is displayed. Enter the patient’s ID number, last name, first name, date of birth, sex, and as many other fields as required or as time will allow (for more information, see “Patient Demographic Fields” on pg. 6-10).
3. A file is automatically created for the patient. Patient information is saved when you press the Left Arrow key to exit the EDIT ID menu.

### Print All New ECGs

If you wish to print all ECGs in the directory which have not been printed previously (i.e., Record Status is not PR), select the PRINT ALL NEW ECGS item in the DIRECTORY.

1. In the DIRECTORY menu, select the PRINT ALL NEW ECGS field by pressing the “E” key.
2. All ECGs which have not been printed previously will print out on the electrocardiograph.



Use the Left Arrow key to exit.

### Print median complex

If you wish to review the averaged beats for a record, select the PRINT MEDIAN COMPLEX item in the DIRECTORY. On interpretive units, the median complex is used as the basis for all computerized analyses.

1. In the DIRECTORY menu, select the **VIEW BY NAME** or **VIEW BY ID** field by pressing either the “N” key or the “I” key (on the Eclipse Plus, select **VIEW DIRECTORY**).
2. Locate the desired patient file, highlight it and press the Enter key. The Single ECG Functions list is displayed.
3. Press the “R” key to print the median complex for the selected record.

**NOTE:** Chart speed is fixed at 50 mm/s.



Use the Left Arrow key to exit.

## Print Measurement Matrix

If you wish to review the numerical data for a record, select the PRINT MEASUREMENT MATRIX item in the DIRECTORY. The measurement matrix contains numerical data, such as P wave duration ("PDUR"), which is derived from the median complex for the record.

1. In the DIRECTORY menu, select the **VIEW BY NAME** or **VIEW BY ID** field by pressing either the "N" key or the "I" key (on the Eclipse Plus, select **VIEW DIRECTORY**).
2. Locate the desired patient file, highlight it and press the Enter key. The Single ECG Functions list is displayed.
3. Press the "N" key to print the measurement matrix for the selected record.



Use the Left Arrow key to exit.

## Configuring the FAX Menu

Eclipse stores up to 4 phone numbers which are listed by their descriptions. Fax numbers and descriptions can be entered or modified from the FAX ECG menu.

1. In the DIRECTORY menu, select the **VIEW BY NAME** or **VIEW BY ID** field by pressing either the "N" key or the "I" key (on the Eclipse Plus, select **VIEW DIRECTORY**).
2. Select any patient file. The Single ECG Functions list is displayed.
3. From the Single ECG Functions list, press the "F" key to access the FAX ECG menu.
4. Press "E" to enter new phone numbers or correct existing numbers in the EDIT PHONE NUMBER menu.
5. To enter a new number for Phone #1, type in a phone number. To modify an existing phone number, arrow down to the phone number and enter the new number as desired.

**NOTE:** Enter up to 20 numeric characters. The comma character ( , ) inserts a pause during dialing. For example, this is often used after dialing a “9” prefix before the rest of the phone number.

6. Arrow down to the Description field. Using the keyboard, type in a description for the phone number.

**NOTE:** Enter up to 15 alphanumeric characters.

7. To add or change additional phone numbers, arrow up or down to the appropriate fields and enter information as desired.



Use the Left Arrow key to exit.

## Print Directory

If you wish to print a list of all patient records currently stored in the directory, select the PRINT DIRECTORY item in the DIRECTORY.

1. In the DIRECTORY menu, select the **PRINT DIRECTORY** field.
2. A complete list of the DIRECTORY contents is printed (see sample printout in Chapter 9).



Use the Left Arrow key to exit.

## Delete All Records

**NOTE:** The below information is for use by IT personnel or network administrators only.

With Eclipse 850 and Eclipse Plus, it is possible to delete all contents in the directory.

**NOTE:** It is not possible to recover erased records.

1. In the DIRECTORY menu, scroll to and select the **DELETE ALL RECORDS** field by pressing the “D” key.
2. A message box will appear. Press the “O” key twice to confirm deletion. To cancel the request, select Cancel.



**NOTE: Proceed with caution.** Answering Ok to these questions will permanently erase every record in the Directory.



Use the Left Arrow key to exit.

**NOTE:** Sending and receiving functions are available on Eclipse units equipped with SCP-ECG capability. You may use a remote connection with either an internal or an external modem or a direct connection with another Eclipse or a compatible ECG management system.

Eclipse 850 and Plus units with communication capabilities can receive requisitions, as well as transmit ECGs to and receive ECGs from other Eclipse electrocardiographs or the PYRAMIS ECG management system.

## How record status affects the sending operations

**NOTE:** For the list of status codes, see “Record Status” on pg. 7-2.

Record status affects whether records can be sent from the Eclipse. The following rules apply:

- Records with status **Dm** can not be sent.
- Records with status **Rv** can not be sent.

In general, the following records will automatically be sent when **BATCH SEND ECGS** is selected in the **DIRECTORY** menu: records with the status **ECG**; records with the status **ECG** and **Pr**; records with the status **RtE**; and records with the status **RtE** and **Pr**. The following rules also apply:

- Records with status **St** or **Rq** will not be sent when **BATCH SEND ECGS** is selected in the **DIRECTORY** menu. These records may be sent individually from the Single ECG Functions list.
- Records with status, **No**, will not be sent when **BATCH SEND ECGS** is selected in the **DIRECTORY** menu. These records may be sent individually from the Single ECG Functions list.

## Changing Record Status

Patient records can be marked so that they are automatically sent when **BATCH SEND ECGS** is selected in the **DIRECTORY** menu. Similarly, patient record status can be changed to ensure that a record is not sent.

### Mark Record as “SEND”

To ensure that a record is sent the next time **BATCH SEND ECGS** is selected, select the **MARK RECORD AS “SEND”** from the Single ECG Functions list.

1. Follow the instructions for accessing the list of patient files (see “Using the **DIRECTORY** Menu” on pg. 7-1).

2. Locate the desired patient file, highlight it and press the Enter key. The Single ECG Functions list is displayed.
3. Select MARK RECORD AS "SEND" from the Single ECG Functions list
4. If the record has been sent previously, then the status of **St** is removed from that record. The file will be sent the next time BATCH SEND ECGS is selected.

### **Mark Record As "DO NOT SEND"**

To ensure that a record is not sent the next time BATCH SEND ECGS is selected, select the MARK RECORD AS "DO NOT SEND" from the Single ECG Functions list.

1. Follow the instructions for accessing the list of patient files (see "Using the DIRECTORY Menu" on pg. 7-1).
2. Locate the desired patient file, highlight it and press the Enter key. The Single ECG Functions list is displayed.
3. Select MARK RECORD AS "DO NOT SEND" from the Single ECG Functions list
4. The record is marked with the **No** status. The file will not be sent the next time BATCH SEND ECGS is selected.

## **Setting up the Unit to Send and Receive**

The Eclipse 850 and the Eclipse Plus can transmit and receive records in two ways:

- Direct Connection
- Remote Connection

A direct connection is achieved through the use of a cable, which connects the Eclipse unit to either PYRAMIS or another Eclipse unit. A remote connection requires either an internal or external modem connected to a phone line.

### **Using a Direct Connection**

1. If you are connecting to PYRAMIS, connect the Interconnect Cable to the connector labeled "DECG-SCP" on the PYRAMIS back panel and to the connector labeled "**IOIO**" on the Eclipse back panel.

2. If you are connecting to another electrocardiograph, connect the Eclipse Direct Connect Cable #007796 to the connectors labeled **"IOIO"** on the back panel of each Eclipse.

**NOTE:** Follow steps 3 through 8 on both Eclipse units.



3. Press the On/Standby key to power up to the PREVIEW screen.
4. Press the "M" key to go to the MAIN MENU.
5. Select SYSTEM SETUP by pressing the "S" key. The SYSTEM SETUP menu will appear (see Figure 4-1 on pg. 4-1).
6. Press the Down Arrow key to highlight the **Connection** field and select **DIRECT**.
7. Press the Left Arrow key to return to the MAIN MENU.
8. Press the "D" key to go to the DIRECTORY menu.

## Using a Remote Connection

### CONNECTING TO PYRAMIS

To send records to PYRAMIS, or to receive requisitions and records from PYRAMIS, the Eclipse 850 or the Eclipse Plus must be equipped with either an internal or external modem connected to a phone line.



1. Press the On/Standby key to power up to the PREVIEW screen.
2. Press the "M" key to go to the MAIN MENU.
3. Select SYSTEM SETUP by pressing the "S" key. The SYSTEM SETUP menu will appear (see Figure 4-1 on pg. 4-1).
4. Press the Down Arrow key to highlight the **Connection** field and select **MODEM**.
5. Verify that the **Phone #** and **Description** fields are correctly filled in.
6. Press the Left Arrow key to return to the MAIN MENU.
7. Press the "D" key to go to the DIRECTORY menu.

### CONNECTING TO ANOTHER ECLIPSE

**NOTE:** This requires two Eclipse units with either an internal or external modem connected to a phone line.



1. **Both Eclipse units:** Press the On/Standby key to power up to the PREVIEW screen.



2. **Both Eclipse units:** Press the “M” key to go to the MAIN MENU.



3. **Both Eclipse units:** Select SYSTEM SETUP by pressing the “S” key. The SYSTEM SETUP menu will appear (see Figure 4-1 on pg. 4-1).



4. On the Eclipse that will be sending records, press the Down Arrow key to highlight the **Description** field and verify that the description and phone number are correct for the electrocardiograph that will be receiving records.



5. **Both Eclipse units:** Press the Down Arrow key to highlight the **Connection** field and select **MODEM**.



6. **Both Eclipse units:** Press the Left Arrow key to return to the MAIN MENU.



7. **Both Eclipse units:** Press the “D” key to go to the DIRECTORY menu.

## Receiving requisitions from PYRAMIS

A requisition is a request for an ECG report that consists of demographic information only. Requisitions are used to organize the schedule of the person acquiring ECG records. An ECG management system such as PYRAMIS sends a requisition to the electrocardiograph, indicating that an ECG needs to be acquired on a specific patient.

Requisitions are received using the GET REQUISITIONS selection in the DIRECTORY menu.

**NOTE:** To receive requisitions from PYRAMIS using a remote connection, the Eclipse 850 or the Eclipse Plus must be equipped with either an internal or external modem connected to a phone line.



1. Follow the instructions for setting up the unit to receive records (see “Setting up the Unit to Send and Receive” on pg. 8-2).

2. From the DIRECTORY menu, press the “Q” key to go to the GET REQUISITIONS menu.

3. Select **ENTER CRITERIA**. The Get Requisitions menu is displayed.

4. The **Department** field will display the default Department number as set in the PATIENT FIELDS ENABLE menu. This will limit the search to requisitions targeted at the selected department. You may change this to receive requisitions for a different department. You can also delete this to receive all requisitions currently on the PYRAMIS system.
5. To limit the request to requisitions targeted at you or your area, type your code into the **Group Code** field.

The Group Code is maintained on the PYRAMIS system. Contact your System Administrator to verify your Group Code.

6. If you want to receive a specific requisition and you know the number, type this number into the **Req. Number (Requisition Number)** field.
7. Press the Left Arrow key to return to the GET REQUISITIONS menu.
8. Select **GET REQUISITIONS** to receive all requisitions that match the criteria you have entered.



## Sending records to PYRAMIS

**NOTE:** To send records to PYRAMIS using a remote connection, the Eclipse 850 or the Eclipse Plus must be equipped with either an internal or external modem connected to a phone line.

1. Follow the instructions for setting up the unit to send records (see "Setting up the Unit to Send and Receive" on pg. 8-2).
2. To send more than one ECG, select **BATCH SEND ECGS** from the DIRECTORY menu. The Eclipse 850 or Plus unit will automatically send all of the ECGs that have the appropriate status (see "How record status affects the sending operations" on pg. 8-1). A message will be displayed indicating the total number of ECGs sent. Select OK.
3. To send a single ECG, in the DIRECTORY menu, select the **VIEW BY NAME** or **VIEW BY ID** field by pressing either the "N" key or the "I" key (on the Eclipse Plus, select **VIEW DIRECTORY**). Select a single record and select **SEND ECG** from the Single ECG Functions list. A message will be displayed indicating the status of the operation. Select OK.
4. The list of tests is displayed.

## Sending and Receiving records from an Eclipse

**NOTE:** To send or receive records from another Eclipse electrocardiograph using a remote connection, both units must be equipped with either an internal or external modem connected to a phone line.

1. Follow the instructions for setting up the unit to send and receive records (see “Setting up the Unit to Send and Receive” on pg. 8-2).

1. Ensure that both electrocardiographs display the DIRECTORY menu.



2. On the Eclipse that will be receiving the records, press the “R” key (**Receive ECGS**) to put the electrocardiograph into waiting mode.

3. To send more than one ECG, select **BATCH SEND ECGS** from the DIRECTORY menu. The Eclipse 850 or Plus unit will automatically send all of the ECGs that have the appropriate status (see “How record status affects the sending operations” on pg. 8-1). A message will be displayed indicating the total number of ECGs sent. Select OK.

4. To send a single ECG, in the DIRECTORY menu, select the **VIEW BY NAME** or **VIEW BY ID** field by pressing either the “N” key or the “I” key (on the Eclipse Plus, select **VIEW DIRECTORY**). Select a single record and select **SEND ECG** from the Single ECG Functions list. A message will be displayed indicating the status of the operation. Select OK.

5. The list of tests is displayed.

## Receiving records from PYRAMIS

**NOTE:** To receive records from PYRAMIS using a remote connection, the Eclipse 850 or the Eclipse Plus must be equipped with either an internal or external modem connected to a phone line.

1. Follow the instructions for setting up the unit to receive records (see “Setting up the Unit to Send and Receive” on pg. 8-2).

2. To receive all confirmed records, select **GET ALL CONFIRMED ECGS** from the DIRECTORY menu. A message

will be displayed indicating the total number of ECGs received. Select OK.

**NOTE:** The Institution Number and Department on the Eclipse must match the settings on PYRAMIS in order for this selection to function properly (see “Institution Number” on pg. 4-4 and “Department” on pg. 6-12).



3. To receive records for a particular patient, select **GET ECG VIA ID** from the DIRECTORY menu. See “Using GET ECG VIA ID” on pg. 8-7).

## Using GET ECG VIA ID

When you select **GET ECG VIA ID** you can search the PYRAMIS database for all the records for a particular patient. You can search the database using:



- The patient’s ID
- The patient’s name

### USING THE PATIENT’S ID

1. From the DIRECTORY menu, select **GET ECG VIA ID**. The GET ECG VIA ID menu is displayed.
2. The only option available at first is **ENTER ID**. Select this option. The GET VIA ID menu is displayed.
3. Type the patient’s ID into the **ID** field.
4.  Press the Left Arrow key to return to GET ECG VIA ID.
5. Select **GET ECG LIST** to view a list of all the records stored on PYRAMIS with that ID.
6. When the list has downloaded, highlight each record that you want to receive and press enter to select the record. The word, “**SELECT**” appears on the right side of the display.
7.  Press the Left Arrow key to return to GET ECG VIA ID.
8. Select **GET ECG(S)** to begin receiving all the selected records.

### USING THE PATIENT’S NAME

1. From the DIRECTORY menu, select **GET ECG VIA ID**. The GET ECG VIA ID menu is displayed.
2. The only option available at first is **ENTER ID**. Select this option. The GET VIA ID menu is displayed.

3. Type at least the first letter of the patient's last name (see "How PYRAMIS Searches Using the Patient's Name").
-  4. Press the Left Arrow key to return to GET ECG VIA ID.
5. Select **GET ECG LIST** to view a list of all the records stored on PYRAMIS with that ID.
6. When the list has downloaded, highlight each record that you want to receive and press enter to select the record. The word, "SELECT" appears on the right side of the display.
-  7. Press the Left Arrow key to return to GET ECG VIA ID.
8. Select **GET ECG(S)** to begin receiving all the selected records.

### HOW PYRAMIS SEARCHES USING THE PATIENT'S NAME

PYRAMIS can search using just the **Last Name** field. All the files with the entered last name are retrieved. If there are no files with exactly the same last name, then PYRAMIS locates all the files with last names that are *similar* to the one entered.

When you search using **First Name** in addition to the **Last Name** field, PYRAMIS searches for files with a first name that matches exactly. First, PYRAMIS searches for an exactly matching last name. If no exact matches are found, PYRAMIS searches for similar last names. Once a last name is found, either matching or similar, PYRAMIS displays only the records in which the first name matches exactly.

#### For example:

The database has 4 records:

Stork, Blanche  
Smythe, John  
Smythe, Blanche  
Smith, Blanche

Search for:

**Last Name:** Smi  
**First Name:** Blanche

PYRAMIS displays 2 records in the *List of Patients* window:

Smythe, Blanche  
Smith, Blanche

No exact match was found for the last name so all names similar to "Smi" were located. Of these, only files with an exactly matching first name were displayed.

Print Directory Report

--- Patient Directory ---			12.11.1995 12.39
Name	ID	Date/Time	Status
MIKKELSON, SCOTT	123000001		DEMOGR Rq
	#STAT#951112123100	12.11.95 12:31	ECG Pr
NICHOLS, JENNIFER	1245678912	12.11.95 11:22	ECG Pr

## **Print Setup Report**

The Print Setup Report is a list of all current settings (see “Acquiring a Printout of Eclipse Program Settings” on pg. 4-16).

The example Print Setup Report printouts on the following pages list the settings as they are set at the factory.





## **Standard 12-Lead, 4-Channel Auto ECG (Eclipse 850)**

## **Standard 12-Lead, 6-Channel Auto ECG (Eclipse 850)**

*[Standard 12-Lead, 6-Channel Auto ECG (continued)]*

## **Standard 3-Channel Rhythm & Manual ECG (Eclipse 850)**

## **Standard 12 Channel Rhythm & Manual ECG (Eclipse Plus)**



While the Eclipse has been refined to consistently produce prompt and accurate results, occasionally you may encounter problems with the Eclipse. Refer to the table in this chapter for solutions to common problems. For any additional questions concerning the operation or servicing of your product, contact your local representative or Spacelabs Technical Support Department at (800) 522-7025, (425) 882-3700 or (608)764-1919.

## Troubleshooting Basic Unit Problems

PROBLEM	PROBABLE CAUSE
Unit will not turn on.	<ul style="list-style-type: none"> <li>- Unit not connected to AC line voltage.</li> <li>- Battery is not installed or has no charge.</li> <li>- Faulty power cord.</li> <li>- AC outlet not functional.</li> </ul>
After the battery has been fully charged, the battery status gauge indicates low battery within 30 minutes of operation.	<ul style="list-style-type: none"> <li>- Battery pack may be worn out.</li> <li>- Battery status gauge is not calibrated (see "Calibration and Charging the Battery" on pg. 2-5).</li> </ul>
Unit "beeps" when a key is pushed.	<ul style="list-style-type: none"> <li>- That function or key is not an option at this time. Press another key to proceed.</li> </ul>
Unit has "frozen." The unit does not respond to key strokes and the display does not change.	<ul style="list-style-type: none"> <li>- Press the On/Standby key. After a possible delay of up to 5 seconds, the unit shuts off. To continue with normal operation, press On/Standby again to restart the Eclipse.</li> </ul>
Unit displays a completely blank screen.	<ul style="list-style-type: none"> <li>- Press the On/Standby key to restart the Eclipse.</li> </ul>
Unit will not send or receive records via modem.	<ul style="list-style-type: none"> <li>- Verify that the phone number and description fields are correctly filled in. These are found in the SYSTEM SETUP menu.</li> <li>- Verify that the correct phone type and connection type are selected in the SYSTEM SETUP menu.</li> </ul>
No records are received from PYRAMIS when using the GET ALL CONFIRMED ECGS in the directory.	<ul style="list-style-type: none"> <li>- No confirmed ECGs currently exist on the PYRAMIS system.</li> <li>- The Institution Number and Department on the Eclipse do not match the settings on PYRAMIS (see "Institution Number" on pg. 4-4 and "Department" on pg. 6-12).</li> </ul>

PROBLEM	PROBABLE CAUSE
Fax function is not working.	<ul style="list-style-type: none"> <li>- Verify that the phone number and description fields are correctly filled in. These are accessed through the FAX ECG menu.</li> </ul>
Several functions in the DIRECTORY menu are unavailable and appear gray.	<ul style="list-style-type: none"> <li>- Verify that the correct connection type is selected in the SYSTEM SETUP menu.</li> <li>- If MODEM is selected for the <b>Connection</b> field, verify that the <b>Phone #</b> field is correctly filled in. These are found in the SYSTEM SETUP menu.</li> </ul>

## Troubleshooting Trace Problems

PROBLEM	PROBABLE CAUSE
Waveforms are flat for all leads and/or "OVERLOAD" message will not clear.	<ul style="list-style-type: none"> <li>- Electrodes not applied correctly.</li> <li>- Acquiring ECG too quickly; wait for the message, "SENSORS OK" before pressing the ECG key.</li> <li>- Patient cable not properly connected to unit.</li> <li>- Faulty patient cable.</li> <li>- Electrical interference from an external source is causing noise spikes.</li> </ul>
Waveform is flat for one or more leads (all others are OK) and/or "OVERLOAD" message will not clear.	<ul style="list-style-type: none"> <li>- Electrode not applied correctly.</li> <li>- Acquiring ECG too quickly; wait for the message, "SENSORS OK" before pressing the ECG key.</li> <li>- Electrode not adhering properly.</li> <li>- Electrode is being pulled, tapped or pressed.</li> <li>- Electrode disconnected from patient's skin.</li> <li>- Lead wire disconnected from electrode.</li> <li>- Debris in teeth of astroclip.</li> <li>- Faulty lead wire(s) or patient cable.</li> </ul>
Baseline is drifting in waveform for one or more leads.	<ul style="list-style-type: none"> <li>- Poor patient preparation.</li> <li>- Use of dissimilar sensors or sensors not recommended for use with Eclipse .</li> <li>- Sensors need to sit longer on skin.</li> <li>- Poor sensor contact with skin.</li> </ul>

PROBLEM	PROBABLE CAUSE
Trace is "noisy." The waveform is not a single, clean line.	<ul style="list-style-type: none"> <li>- AC interference from lighting, cables, or equipment near patient.</li> <li>- Improper line filter setting in SYSTEM SETUP menu.</li> </ul>
Occasional noise or artifact in the waveform for one or more leads.	<ul style="list-style-type: none"> <li>- Patient movement.</li> <li>- Muscle tremor noise.</li> <li>- Improperly applied sensors.</li> <li>- Electrical interference.</li> <li>- Sensors need to sit longer on skin.</li> <li>- Poor sensor contact with skin.</li> <li>- Ineffective baseline filter setting.</li> </ul>
Incorrect heart rate printed and/or displayed.	<ul style="list-style-type: none"> <li>- Waveform is a bigeminal rhythm.</li> <li>- Poor data quality. Ensure that the sensors and leads are attached properly.</li> <li>- QRS amplitude and T wave amplitude are almost the same.</li> </ul>
Incorrect or missing measurements on the printout.	<ul style="list-style-type: none"> <li>- Undetermined P-wave or P-T coupling.</li> <li>- Poor data quality. Ensure that the sensors and leads are attached properly.</li> <li>- Unusual waveform pattern.</li> </ul>

## Troubleshooting Printer Problems

PROBLEM	PROBABLE CAUSE
Paper jammed or misaligned.	<ul style="list-style-type: none"> <li>- Unit not used for extended period of time with paper installed. Reload paper, see page 2-6.</li> </ul>
Print quality is very light.	<ul style="list-style-type: none"> <li>- Paper type in use is Assurance 50, but paper type selected in system settings is Standard. Change paper type in settings to Assurance 50 (see "Paper Type" on pg. 4-5).</li> </ul>
Print quality is very dark.	<ul style="list-style-type: none"> <li>- Paper type in use is Standard, but paper type selected in system settings is Assurance 50. Change paper type in settings to Standard (see "Paper Type" on pg. 4-5).</li> </ul>

PROBLEM	PROBABLE CAUSE
Problems using full format paper.	<ul style="list-style-type: none"> <li>- Load paper (see "Loading Recording Paper" on pg. 2-6)</li> <li>- Ensure the paper is at top-of-form by pressing the "P" key and waiting until the paper stops. If "Paper OUT: Reload and continue?" message appears, select OK.</li> <li>- Press "MAN". When printing starts, press "STOP".</li> <li>- Again, press "MAN". When printing starts, press "STOP".</li> </ul>
REDUCED PERFORMANCE MODE Paper speed erratic. ECG printouts have unexpected breaks in the waveforms at random intervals. Breaks are accompanied by vertical dashed lines, header/footer information and lead designators.	<ul style="list-style-type: none"> <li>- 50 mm/s paper speed selected. Reduce paper speed to 25 mm/s.</li> <li>- Artifact filter is set to 40 Hz (on). Change setting to 150 Hz.</li> <li>- Current Custom Lead setting is Frank. Use another Custom Lead setting or reduce paper speed and turn off Artifact Filter.</li> </ul>
Report is printing "STAT" in the Patient ID field of the report.	<ul style="list-style-type: none"> <li>- No ID number was entered for the patient.</li> </ul>

## Recognizing and Reducing ECG Artifacts

### "OVERLOAD" message

Defibrillating the patient will interfere with the Eclipse sensors. This may result in loss of the trace or erratic trace deflections. An "OVERLOAD" message alerts you that waveforms may not be accurate. To speed recovery time after defibrillation press the "B" key to activate the Defibrillation Recovery filter (see "The Defibrillation Recovery filter" on pg. 10-6).

A broken wire in a patient lead or a poorly applied sensor may also cause an "OVERLOAD" message. This condition must be corrected before the overload condition clears.

### Rapid, large and erratic deflections

A broken wire in the patient lead or a poorly applied sensor may cause rapid, large and erratic trace deflections.

### Irregular frequency or amplitude

Patient movement and muscle tremor may result in abnormal traces. To minimize this artifact, toggle the artifact filter to 40 Hz with the "9" machine control key.

In addition, try to gain the patient's cooperation in staying very relaxed and still. Sometimes, somatic tremor is unavoidable but its effects may be minimized by having the patient place his/her hands under the buttocks.

Figure 10-1  
Somatic Tremor and Patient  
Movement Artifact

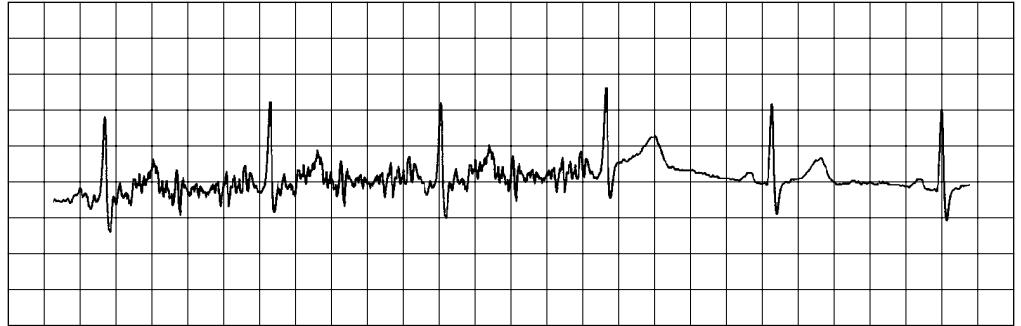

### Baseline wander

Poorly affixed sensors may cause the baseline to wander. Normally, the baseline will stabilize within a few seconds. If the baseline shifts up and down, it may be due to the patient's breathing or to loose or corroded sensors.

Figure 10-2  
Poorly Affixed Sensor  
Artifact

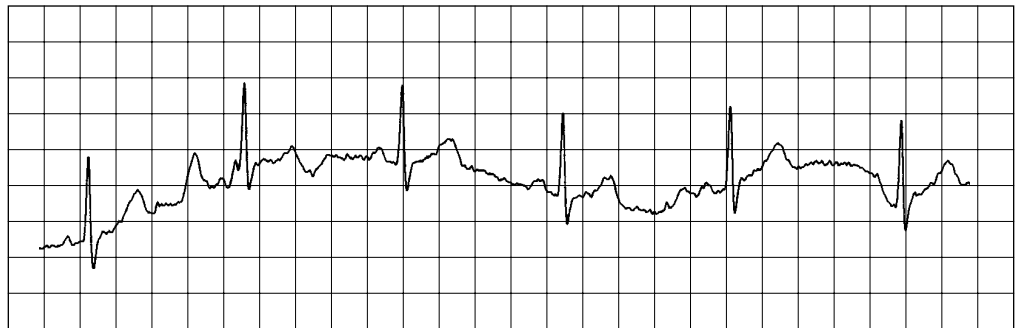

### Wide baseline

Electrical interference may produce a wide baseline. Its amplitude depends on the strength of the current source and the lead being recorded. In any one lead, the amplitude of the interfering signal is uniform.

Figure 10-3  
Electrical Interference  
Artifact

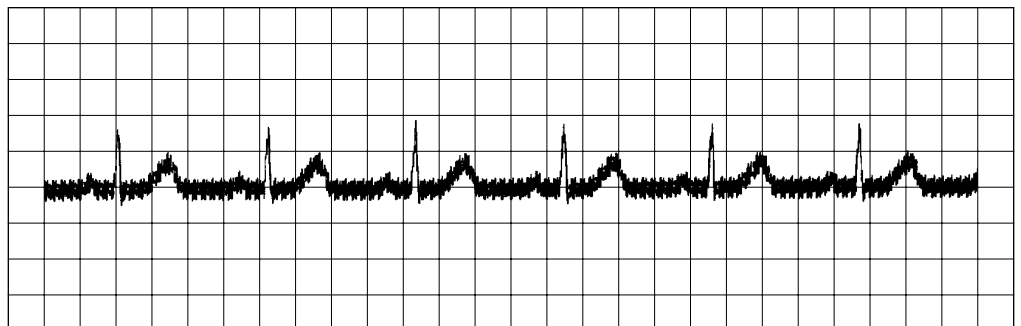

To reduce electrical interference:

- ✓ Keep the power cord away from the patient and patient cable.
- ✓ Connect the unit to a properly grounded wall outlet.
- ✓ Arrange the patient cable leads together, closely following the body contour.
- ✓ Check the line filter setting in the SYSTEM SETUP menu. For more information, see “Configuring SYSTEM SETUP Menu” on pg. 4-1.
- ✓ Ensure that Diathermy or X-ray equipment in adjacent rooms is not operating. Other electrical equipment including electric beds, televisions, and lighting fixtures may also generate interference (even when not in use).
- ✓ Try moving the patient to another place in the room. Sometimes, electrical wiring in walls and ceilings causes interference.
- ✓ Operate the Eclipse from battery power.

## The Defibrillation Recovery filter

NOTE: The Defibrillation Recovery filter should be used only for enhanced recovery time after defibrillation to confirm the presence of cardiac activity. While this filter is enabled, waveforms printed are not of diagnostic quality. Care must be taken by the operator to not misinterpret the patient’s condition during an “OVERLOAD” condition.

The Eclipse provides a Defibrillation Recovery filter for faster recovery time from an “OVERLOAD” condition caused by defibrillation (see ““OVERLOAD” message” on pg. 10-4).

This filter is enabled by pressing the “B” key. Do this only after defibrillation and only if the trace does not recover. When the filter is enabled, the Sensor Status message in the PREVIEW screen displays “FAIL” and “OVERLOAD” is printed on the report. After approximately 30 seconds, the filter clears and the Eclipse returns to normal operation.

**NOTE:** To ensure safety of patients and operators, periodic safety checks should be performed by a qualified service technician trained in medical device safety.

## Calibrating the Battery Status Gauge

Whenever a new battery is placed in the Eclipse or whenever the battery is removed and re-installed, the Battery Status gauge in the PREVIEW screen should be calibrated. In addition, it is recommended that you follow this procedure every 60 days to maintain maximum battery capacity. This is especially important if the unit is infrequently operated with battery power.

**NOTE:** The Eclipse 850 does not have a Battery Status gauge, however it is still a good idea to perform this procedure to condition the battery and maintain maximum capacity.

1. Unplug the Eclipse from AC line power.
2. Press ON/STBY to turn the Eclipse on. Press M to go to the Main menu. Press B, then press O (OK) to turn on the Battery Exercise Mode.
3. Fully discharge the battery by operating the unplugged unit until the unit powers down from lack of power.
4. Ensure that the battery is discharged by pressing the On/Standby key. If the unit does not turn on or if it powers down within a few seconds, the battery is discharged.
5. Reconnect AC power to fully recharge the battery in about 5 hours.

**NOTE:** You may operate the Eclipse from AC line power while the battery is charging. However, this will increase charging time.

## Inspecting for Damage



**WARNING:** *Hazardous voltage. To reduce the risk of electrical shock, do not attempt to remove the cover under any circumstances. Refer servicing to a qualified technician.*

Before every use, check the power cord, power plug, power connector, and power input jack for signs of damage.

Contact an authorized service agent immediately if:

- ✓ The equipment falls from the cart or is subjected to some other extreme mechanical stress.
- ✓ Liquid is spilled on the equipment.
- ✓ The equipment is not functioning properly.
- ✓ Parts of the enclosure are cracked, missing or deteriorated.
- ✓ Any connector or cord shows signs of deterioration such as cracking.

## Cleaning and Disinfecting the Eclipse

Clean and disinfect the unit any time it is deemed necessary.

### The housing

NEVER use ether, benzene or similar solvents.

#### CLEANING

Gently rub the housing with a clean, damp cloth using a mild household detergent.

#### DISINFECTION

Spray the housing with INCIDIN or similar product.

### The patient cable and reusable sensors

NEVER immerse cables in fluid, or use hot sterilization. Do not use ether. Do not use bleach, acetone or similar harsh chemicals or solvents.

#### CLEANING AND DISINFECTION

Rub with a clean cloth moistened with a formaldehyde solution such as CIDEX, SONACIDE, LYSOFORM 5% or INCIDIN 1.5%.

---

---

## Testing Equipment

The Eclipse performs a computer self-test every time it is powered up. No calibration is necessary. Complete safety and component checks should be performed at least annually by a qualified service technician.

### Testing the Patient cable

If the patient cable appears damaged in any way, contact your local representative for replacement.

- Visually inspect for the cable for cracks, stress marks and broken or bent pins.
- Connect the patient cable to the ECG and attach each sensor lead to an electronic heart signal simulator. (If a simulator is not available, a test subject may be used.)
- Check the signal transmission through the cable by flexing the cable and electrode lead wires and observing the ECG rhythm for irregular tracings.

**NOTE:** If using a test subject, be sure not to disturb the sensor site since common baseline artifact will occur. This should not be confused as a broken wire.

### Testing the battery

The Eclipse monitors battery status. It is not necessary for you to perform any tests on the battery. However, if the battery does not retain a charge for more than 30 minutes of operation, you may need to condition or replace the battery pack. To condition the battery pack, perform the steps outlined in “Calibration and Charging the Battery” on pg. 2-5. Even though the Eclipse 850 does not have a battery status gauge, it is still recommended that you perform the calibration procedure to condition the battery. Battery replacement is described earlier in this chapter. The battery pack in the Eclipse Plus is not user replaceable. It must be replaced by an authorized service representative.



**WARNING:** *Never remove the battery pack and attempt to recharge it using an external battery charger. Fire or explosion may result.*

## Quick Reference-Replacing the Battery (Eclipse 850)



**WARNING:** *Never remove the battery pack and attempt to recharge it using an external battery charger. Fire or explosion may result.*

**CAUTION:** *Fire hazard. Use only an approved battery pack. Replace Eclipse 850 battery pack with the battery specified on the label inside the battery compartment.*



**NOTICE:** Do not place used battery pack in your regular trash. The incineration, landfilling, or mixing of NiCd batteries with municipal waste is **PROHIBITED BY LAW** in most areas. Return this battery pack to a government-approved battery recycler. Contact your local waste management officials for more information.

### Removal

1. Turn unit over to expose battery cover.
2. Depress battery cover latch and slide cover out.
3. Lift battery pack and disconnect battery by grasping the connector and sliding it straight out.

**DO NOT PULL ON WIRES!**

### Installation

1. Slide battery connector on to PC board. (Battery connector is polarized and made to fit only one way; Do not force connector into slot.)
2. Place battery pack into battery compartment:

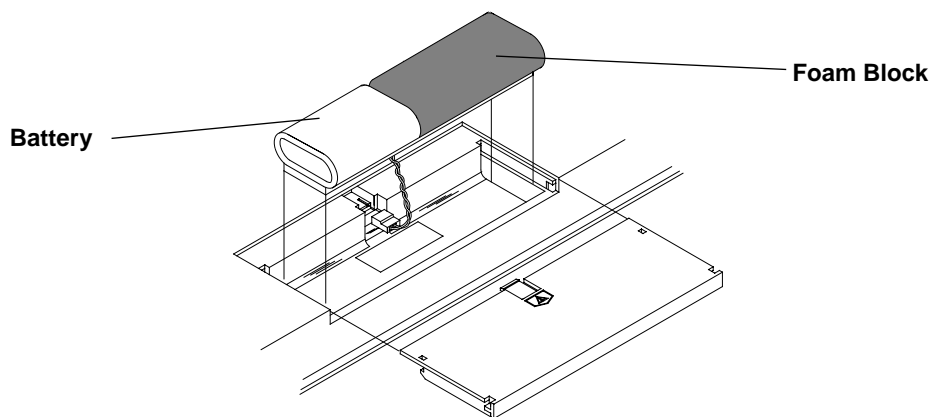

3. Arrange battery connector wires so that they will not interfere with battery cover.
4. Place foam block in battery compartment.
5. Position battery cover over battery compartment and slide forward until it snaps into place.

## Notice to responsible service personnel

The contents of this document are not binding. If you find a significant difference between this service information and your unit, please consult your local representative. We reserve the right to improve or modify products without amending this document or advising the user.

We recommend consulting authorized personnel for all service and repairs, and using genuine parts, exclusively. Spacelabs Burdick, Inc. will not otherwise assume responsibility for material quality, workmanship or any consequences thereof.

This product has been carefully designed and manufactured to provide a high degree of safety and dependability. However, we can not guarantee against the failure or deterioration of components due to aging and normal use.

## Performance Disclosures



**WARNING:** *Explosion hazard. Do NOT use in the presence of flammable anesthetics.*



**WARNING:** *This device is NOT intended for unattended or continuous patient monitoring. It is intended for short-term ECG waveform acquisition. There are no audible or visible alarms.*

**CAUTION:** *Although the Eclipse is designed to meet IEC 601-1-2 EMC immunity requirements, the presence of strong EMI fields generated by electronic, surgical or diathermy instruments in close proximity to the unit may cause trace noise or input overload conditions.*

**NOTE:** Deviations from the technical specification ranges listed can affect device performance.

**NOTICE:** Computer assisted interpretation is a valuable tool when used properly. However, no automated interpretation is completely reliable and interpretations should be reviewed by a qualified physician before treatment, or non-treatment, of any patient.

**NOTICE:** Because the Eclipse offers several different lead configurations, always ensure that the appropriate lead placement is employed for the lead configuration selected.



This symbol which appears on the rear panel of some units, indicates this equipment meets the requirements of Council Directive 93/42/EEC, MDD, Class IIa.

These units have been tested for electromagnetic compatibility in accordance with IEC 601-1-2. The failure criterion for the device is, “undetectable interference with the ECG trace which could result in misdiagnosis.” While the device passes the relevant standards, it may exhibit evidence of interference when subjected to electrostatic discharges, high voltage transients or high voltage surges, as defined in IEC 801-2, IEC 801-4 and IEC 801-5. The interference from a single event will demonstrate as a sharp noise spike on the ECG trace. The clinician will not confuse such a noise spike with the heart beat waveforms and there is no hazard of misdiagnosis. In the unlikely situation that the equipment is placed in an environment where such interference events are common, either the equipment or the interference source may be moved.

### **Battery pack**

Under normal conditions, a fully charged battery pack provides adequate power to print a minimum of 200 pages of data at paper speed of 25 mm/sec; or a minimum of 20 minutes of continuous acquisition and printing.

A fully discharged battery pack will completely recharge in approximately 5 hours.

### **Heart rate detection**

The Eclipse heart rate meter is specified to function in the range of 30 to 250 bpm with a tolerance of  $\pm 10\%$  or  $\pm 5$  bpm, whichever is greater. Question marks (???) appear on the printout if the heart rate is out of the specified range.

## Technical Specifications (Eclipse 850)

<b>Dimensions:</b>	299mm x 462mm x 105mm (11.75" x 18.16" x 4.14")
<b>Weight (unit only):</b>	6.45 kg (14.2 lbs)
<b>Power Requirements:</b>	
mains power requirement	115/230 V AC $\pm$ 10%, 0.80/0.40 A, 50/60 Hz
battery operation	16.8 VDC NiCd battery pack
<b>Fuses:</b>	
F1 and F2 mains	for 115 V, 1.0 A 250 V type T for 230 V, 0.500 A 250 V type T
<b>Environmental:</b>	
operating temperature	10° C to 40° C
storage temperature	-20° C to 55° C
relative humidity	25% to 95% non-condensing
atmospheric pressure	7 x 10 <sup>4</sup> to 10.6 x 10 <sup>4</sup> Pa
<b>Acquisition:</b>	
lead selection	I, II, III, aVR, aVL, aVF, V1, V2, V3, V4, V5, V6 Supports Frank X,Y,Z; Nehb D,A,J; and Alternate Chest Lead
interpretation (if equipped)	diagnosis, measurements, reasons statements
modes	auto, rhythm, manual
frequency response	meets or exceeds ANSI/AAMI EC11-1991 standard
input impedance	meets or exceeds ANSI/AAMI EC11-1991 standard
electrode offset tolerance	$\pm$ 300 mV
a/d conversion	5 $\mu$ V LSB
<b>Storage Resolution:</b>	500 samples/sec, 5 $\mu$ V resolution
<b>Artifact Filter Response:</b>	40 Hz, -3dB
<b>Display:</b>	320 x 240 pixel, backlit Liquid Crystal Display (LCD)
<b>Printout:</b>	
paper type	thermal sensitive
chart speeds	10, 25, 50 mm/sec (meets or exceeds ANSI/AAMI EC11-1991 standard)
gain	5, 10, 20 mm/mV (meets or exceeds ANSI/AAMI EC11-1991 standard)
printout formats	3, 4, 6 or 12 channels; additional rhythm formats
printout device	216mm thermal dot array
paper dimension	8.5" x 11" Center-folded 210mm x 300mm (A4) Center-folded

**Input/Output:**

(units with communications)

standard RS-232 (9 pin "D")

analog output (25 pin D connector)

telephone line interface (RJ11C)

**Equipment Type**

Class IIa (Council Directive 93/42/EEC, MDD)

**Conforms to Standards:**

IEC 601-1/CSA C22.2 no. 601-1-M90

IEC 601-2-25/CSA C22.2 no. 601-2-25

IEC 601-1-2

And, by reference of IEC 601-1-2, conforms to EN 55011-Class A, IEC 801-2, IEC 801-3, IEC 801-4 and IEC 801-5.

AZ/NZS 2064.1/2

**Safety:**

leakage current

patient <10 $\mu$ A, chassis <100 $\mu$ A

defibrillator protection

to 5000V, 400J

## Technical Specifications (Eclipse Plus)

<b>Dimensions (with cart):</b>	43.5cm x 65.1cm x 125.7cm (17.125" x 25.625" x 49.5")
<b>Weight (with cart):</b>	39.5 kg (87 lbs)
<b>Power Requirements:</b>	
mains power requirement	115/230 V AC $\pm$ 10%, 0.80/0.40 A, 50/60 Hz
battery operation	16.8 VDC NiCd battery pack
<b>Fuses:</b>	
F1 and F2 mains	for 115 V, 1.0 A 250 V type T for 230 V, 0.500 A 250 V type T
<b>Environmental:</b>	
operating temperature	10° C to 40° C
storage temperature	-20° C to 55° C
relative humidity	25% to 95% non-condensing
<b>Acquisition:</b>	
atmospheric pressure	$7 \times 10^4$ to $10.6 \times 10^4$ Pa
lead selection	I, II, III, aVR, aVL, aVF, V1, V2, V3, V4, V5, V6 Supports Frank X, Y, Z; Nehb D, A, J; and Alternate chest lead
interpretation	diagnosis, measurements, reasons statements
modes	auto, rhythm, manual
frequency response	meets or exceeds ANSI/AAMI EC11-1991 standard
input impedance	meets or exceeds ANSI/AAMI EC11-1991 standard
electrode offset tolerance	$\pm$ 300 mV
a/d conversion	5 $\mu$ V LSB
<b>Storage Resolution:</b>	500 samples/sec, 5 $\mu$ V resolution
<b>Artifact Filter Response:</b>	40 Hz, -3dB
<b>Display:</b>	640 x 480 pixel Active-Matrix, Color, Liquid Crystal Display (LCD)
<b>Printout:</b>	
paper type	thermal sensitive
chart speeds	10, 25, 50 mm/sec (meets or exceeds ANSI/AAMI EC11-1991 standard)
gain	5, 10, 20 mm/mV (meets or exceeds ANSI/AAMI EC11-1991 standard)
printout formats	3, 4, 6 or 12 channels; additional rhythm formats
printout device	216mm thermal dot array
paper dimension	8.5" x 11" Z-fold or 210mm x 300mm (A4) Z-fold

**Input/Output:**

standard RS-232 (9 pin "D")  
analog output (8 pin DIN)  
expansion connector (6 pin DIN)  
telephone line interface (RJ11C)  
PCMCIA slot (type 3)

**Equipment Type**

Class IIa (Council Directive 93/42/EEC, MDD)

**Conforms to Standards:**

IEC 601-1/CSA C22.2 no. 601-1-M90  
IEC 601-2-25/CSA C22.2 no. 601-2-25  
IEC 601-1-2  
And, by reference of IEC 601-1-2, conforms to EN  
55011-Class A, IEC 801-2, IEC 801-3, IEC 801-4  
and IEC 801-5.  
AZ/NZS 2064.1/2

**Safety:**

leakage current	patient <10 $\mu$ A, chassis <100 $\mu$ A
defibrillator protection	to 5000V, 400J

Eclipse models with interpretation or measurement capabilities can be programmed to print the Measurement Matrix after the analysis report.

The Measurement Matrix consists of 12 columns which contain measurements for the twelve standard leads. These columns are labelled I, II, III, aVR, aVL, aVF, V1, V2, V3, V4, V5, V6.

The following table explains the numerical values in the Measurement Matrix.

<b>MEASUREMENT</b>	<b>DESCRIPTION</b>
<b>PON</b>	Time in milliseconds from the beginning of recording to the beginning of the first P wave.
<b>PDUR</b>	P wave duration in milliseconds.
<b>QRSON</b>	Time in milliseconds from the beginning of recording to the beginning of the QRS complex.
<b>QRS DUR</b>	QRS duration in milliseconds.
<b>QDUR</b>	Q wave duration in milliseconds.
<b>RDUR</b>	R wave duration in milliseconds.
<b>SDUR</b>	S wave duration in milliseconds.
<b>R'DUR</b>	R' wave duration in milliseconds.
<b>S'DUR</b>	S' wave duration in milliseconds.
<b>P+DUR</b>	P+ wave duration in milliseconds.
<b>QRSDEF</b>	Intrinsicoid deflection time.
<b>P+AMP</b>	P+ wave amplitude in microvolts.
<b>P-AMP</b>	P- wave amplitude in microvolts.
<b>QRSP2P</b>	Peak to peak amplitude of the QRS complex.
<b>QAMP</b>	Q wave amplitude in microvolts.
<b>RAMP</b>	R wave amplitude in microvolts.
<b>SAMP</b>	S wave amplitude in microvolts.
<b>R'AMP</b>	R' wave amplitude in microvolts.
<b>S'AMP</b>	S' wave amplitude in microvolts.

**MEASUREMENT**

**DESCRIPTION**

**STAMP**

ST wave amplitude in microvolts.

**2/8STT**

Amplitude in microvolts at a point which is 2/8 of the ST-T interval.

**3/8STT**

Amplitude in microvolts at a point which is 3/8 of the ST-T interval.

**T+AMP**

T+ wave amplitude in microvolts.

**T-AMP**

T- wave amplitude in microvolts.

**QRSAR**

Total area of the QRS complex in microvolts/millisecond.

**TMORPH**

T wave morphology.

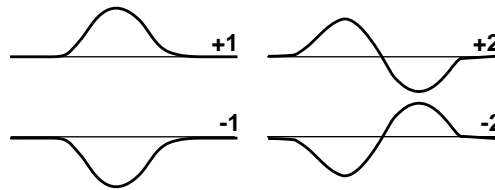

**RWNCH**

R wave notch count.

**DWCON**

Probability (in %) of the presence of a delta wave.

**STSLOP**

ST slope in degrees.

**TON**

Time in milliseconds from the beginning of the recording to the beginning of the T wave.

**TDUR**

T wave duration in milliseconds.

**T+DUR**

T+ wave duration in milliseconds.

**QTINT**

QT interval in milliseconds

---

---

# Index

## A

- Acquiring ECG Reports
  - Acquiring a Stat ECG, 6-1
  - Acquiring an Auto ECG, 6-2
  - Acquiring an Auto Rhythm, 6-6
- Add New Patient, 7-6
- AUTO ECG SETUP menu, 4-8

## B

- Battery
  - Battery pack, Performance Disclosures, 11-6
  - Calibrating the Battery Status Gauge, 2-5
  - Quick Reference-Replacing the Battery (Eclipse 850), 11-4
  - Testing the battery, 11-3

## C

- Calendar & Clock settings, 4-5
- Cautions, v
- Choosing the environment, 5-1
- Cleaning and Disinfecting the Eclipse, 11-2
  - The housing, 11-2
  - The patient cable and reusable sensors, 11-2
- Custom Header, Getting Customer Header Information, 4-15
- CUSTOM LEAD 1 & CUSTOM LEAD 2 menus, 4-9
  - Eclipse 850, 4-10
  - Eclipse Plus, 4-10

## D

- Deleting Files, 7-5
  - Delete All Records, 7-8
- DIRECTORY Menu, 7-1
  - Automatic deletion when the Directory is full, 7-3

## E

- Entering Patient Demographics, 6-9
- Equipment Setup, 2-1

- Calibrating the Battery Status Gauge, 2-5
- Connecting Power, 2-4
- Connecting power cord and peripheral equipment, 2-1
- Connecting the Patient Cable and Enhancing Software, 2-3
- Equipment Connections, 2-1
- Quick Reference-Loading Recording Paper, 2-6
- Turning the Unit On and Off, 2-6

## F

- Faxing Reports, 7-5
  - FAX ECG Menus, 7-7

## G

- Get ECG Via ID, 8-7
  - How PYRAMIS Searches Using the Patient's Name, 8-8
  - Using The Patient's ID, 8-7
  - Using The Patient's Name, 8-7

## H

- Hot Keys, 3-9

## I

- Inspection Upon Delivery, 1-1
- Intended Use, iii
- Interpretive Analysis Program, 1-3

## K

- Keyboard, 3-1
  - Alphabetic, 3-3
  - Arrow, 3-3
  - Backspace, 3-3
  - Brightness, 3-3
  - Enter, 3-3
  - Function, 3-2
  - Numeric/ Machine Control, 3-2
  - On/Standby, 3-3
  - Shift, 3-3
  - Space, 3-3

## L

- Lead Placement
  - Frank: Corrected Orthogonal Leads, 5-7
  - Nehb: Bipolar Leads, 5-8
  - Pediatric, 5-7
  - Resting ECG Lead Placement & Coding Chart, 5-3
- Lists, 3-9

## M

- Maintenance, 11-1
  - Inspecting for Damage, 11-2
  - Notice to responsible service personnel, 11-5
  - Quick Reference-Replacing the Battery (Eclipse 850), 11-4
  - Testing Equipment, 11-3
- Mark Record
  - Mark Record As "Do Not Send", 8-2
  - Mark Record as "send", 8-1
- Measurement Matrix, 12-1
- Menus, 3-10
  - A sample menu—the EDIT ID menu, 3-6
  - Alphanumeric Fields, 3-8
  - Defaults, 3-8
  - List fields, 3-8
  - Numeric fields, 3-8
- MISCELLANEOUS menu, 4-12

## N

- Notices, v

## P

- Patient Demographic Fields, 4-13
  - Edit Patient Demographics, 7-3
- Patient Preparation
  - Applying chest sensors, 5-4
  - Applying ECG Sensors, 5-2
  - Applying limb plates, 5-5
  - Applying limb sensors, 5-4
  - Applying Welsh bulb chest sensors, 5-6
  - Connecting the Patient Cable to the Eclipse, 5-6
  - Using Disposable ECG Sensors, 5-4

---

Using Reusable ECG Sensors, 5-5

Patient preparation

- Lead placement, 5-11

Performance Disclosures, 11-5

POWER-UP DEFAULTS menu, 4-7

PREVIEW Screen, 3-4

Printing Reports, 6-6, 7-3

- Print Directory, 7-8
- Print Measurement Matrix, 7-7
- Print Median Complex, 7-6
- Print Setup Report, Eclipse 4, 9-2
- Print Setup Report, Eclipse 850, 9-3
- Print Setup Report, Eclipse Plus, 9-4

Printouts

- Eclipse Settings, 4-16
- Standard 12 Channel Rhythm & Manual ECG (Eclipse Plus), 9-9
- Standard 12-Lead, 4-Channel Auto ECG (Eclipse 850), 9-5
- Standard 12-Lead, 6-Channel Auto ECG (Eclipse 850), 9-6
- Standard 3-Channel Rhythm & Manual ECG (Eclipse 850), 9-8

## R

Receive ECGs, 8-1

- Receiving records from PYRAMIS, 8-6

Record Status, 7-2

Requisitions

- Receiving requisitions from PYRAMIS, 8-4

## S

Safety

- Safety Features, 1-4
- Using Multiple Electrical Apparatus, 1-4

Send ECGs, 8-1

- How record status affects the sending operations, 8-1
- Sending records to an Eclipse, 8-6
- Sending records to PYRAMIS, 8-5

Speed, Gain, Filter, 7-4

Symbols, vi

- Labelling Symbols, vii
- Safety Symbols, vi

System Notes, 3-9

System Setup, 4-1

## T

Technical Specifications (Eclipse 850), 11-7

Technical Specifications (Eclipse Plus), 11-9

Troubleshooting, 10-1

- “OVERLOAD” message, 10-4
- Baseline wander, 10-5
- Irregular frequency or amplitude, 10-4
- Rapid, large and erratic deflections, 10-4
- Recognizing and Reducing ECG Artifacts, 10-4
- The Defibrillation Recovery filter, 10-6
- Troubleshooting Basic Unit Problems, 10-1
- Troubleshooting Printer Problems, 10-3
- Troubleshooting Trace Problems, 10-2
- Wide baseline, 10-5

## U

USER SETUP Menus, 4-5

## W

Warnings, iv

## FCC CONNECTION INFORMATION

This equipment complies with Part 68 of the FCC Rules. On the bottom of this equipment is a label that contains, among other information, the FCC Registration Number and ringer equivalence number (REN) for this equipment. If requested, this information must be provided to the telephone company.

The REN is used to determine the quantity of devices that may be connected to the telephone line. Excessive RENs on the telephone line may result in devices not ringing in response to an incoming call. In most, but not all areas, the sum of the RENs should not exceed five (5.0). To be certain of the number of devices that may be connected to the line, as determined by the total RENs, contact the telephone company to determine the total REN for the calling area.

If your Eclipse™ causes harm to the telephone network, the telephone company will notify you in advance that temporary discontinuance of service may be required. But if advance notice isn't practical, you will be notified as soon as possible. Also, you will be advised of your right to file a complaint with the FCC if you believe it is necessary.

The telephone company may make changes in its facilities, equipment, operations, or procedures that could effect the operation of the equipment. If this happens, the telephone company will provide advance notice in order for you to make the necessary modifications in order to maintain uninterrupted service.

If you experience trouble with your Eclipse™, please contact Spacelabs Burdick, Inc., 500 Burdick Parkway, Deerfield, WI 53531, U.S.A., phone: (800) 333-7770 or (608) 764-2381 for repair/warranty information. If the trouble is causing harm to the telephone network, the telephone company may request you remove the equipment from the network until the problem is solved.

This equipment may not be used on coin service provided by the telephone company. Connection to Party Line Service is subject to state tariffs. (Contact the state public utility commission, public service commission, or corporation commission for information.)

This device is equipped with a USOC RJ11C connector

## EQUIPMENT ATTACHMENT LIMITATIONS

**NOTICE:** The Canadian Department of Communications label identifies certified equipment. This certification means that the equipment meets certain telecommunications network protective, operational, and safety requirements. The Department does not guarantee the equipment will operate to the user's satisfaction.

Before installing this equipment, user's should ensure that it is permissible to be connected to the facilities of the local telecommunications company. The equipment must also be installed using an acceptable method of connection. In some cases, the company's inside wiring associated with a single-line individual service may be extended by means of a certified connector assembly (telephone extension cord). The customer should be aware that compliance with the above conditions may not prevent degradation of service in some situations.

Repairs to certified equipment should be made by an authorized Canadian maintenance facility designated by the supplier. Any repairs or alterations made by the user to this equipment, or equipment malfunctions, may give the telecommunications company cause to request the user to disconnect the equipment.

User's should ensure for their own protection that the electrical ground connections of the power utility, telephone lines, and internal metallic water pipe system, if present, are connected together. This precaution may be particularly important in rural areas.

**CAUTION:** Users should not attempt to make such connections themselves, but should contact the appropriate electric inspection authority, or electrician, as appropriate.

The LOAD NUMBER (5) assigned to each terminal device denotes the percentage of the total load to be connected to a telephone loop, which is used by the device to prevent overloading. The termination on a loop may consist of any combination of devices subject only to the requirement that the total of the Load Numbers of all of the devices does not exceed 100.

**SERVICE STATION:** If you have any questions or trouble, please contact Spacelabs Burdick, Inc., 500 Burdick Parkway, Deerfield, WI 53531, U.S.A., phone: (800) 777-1777 or (608) 764-1919.

